

# Wireless World

RADIO AND ELECTRONICS

JULY  
1948

38th YEAR OF PUBLICATION

Proprietors : ILIFFE & SONS LTD.

Managing Editor : HUGH S. POCOCK, M.I.E.E.

Editor : H. F. SMITH

Editorial, Advertising and Publishing Offices :

DORSET HOUSE, STAMFORD STREET,  
LONDON, S.E.1.

Telephone :  
Waterloo 3333  
(60 lines).

Telegrams :  
"EthaWorld, Sedist,  
London."

PUBLISHED MONTHLY

Price : 1/6

(Publication date 26th of preceding month)

Subscription Rate : 20/- per annum. Home and  
Abroad

Branch Offices :

Birmingham : King Edward House, New Street, 2.

Coventry : 8-10, Corporation Street,

Glasgow : 26B, Renfield Street, C.2.

Manchester : 260, Deansgate, 3.

## In this Issue

EDITORIAL COMMENT .. .. .	239
WHY ALIGN DISCRIMINATORS ? By Thomas Roddam .. .. .	240
V.H.F. FOR CIVIL AIRCRAFT .. .. .	242
SINGLE SIDEBAND SELECTOR By A. Dinsdale .. .. .	244
GAS MOLECULES AS RESONATORS .. .. .	248
ELECTRONIC CIRCUITRY By J. McG. Sowerby .. .. .	249
"SURPLUS" TELEVISION RECEIVER By L. J. Dalby .. .. .	251
MODULATION, ETC. By "Cathode Ray" .. .. .	253
MILLIMETRE WAVELENGTHS .. .. .	258
WORLD OF WIRELESS .. .. .	259
NEW INTERNATIONAL CALL SIGNS .. .. .	262
SHORT-WAVE CONDITIONS .. .. .	263
UNBIASED By "Free Grid" .. .. .	264
LETTERS TO THE EDITOR .. .. .	265
RANDOM RADIATIONS By "Diallist" .. .. .	268
RECENT INVENTIONS .. .. .	270

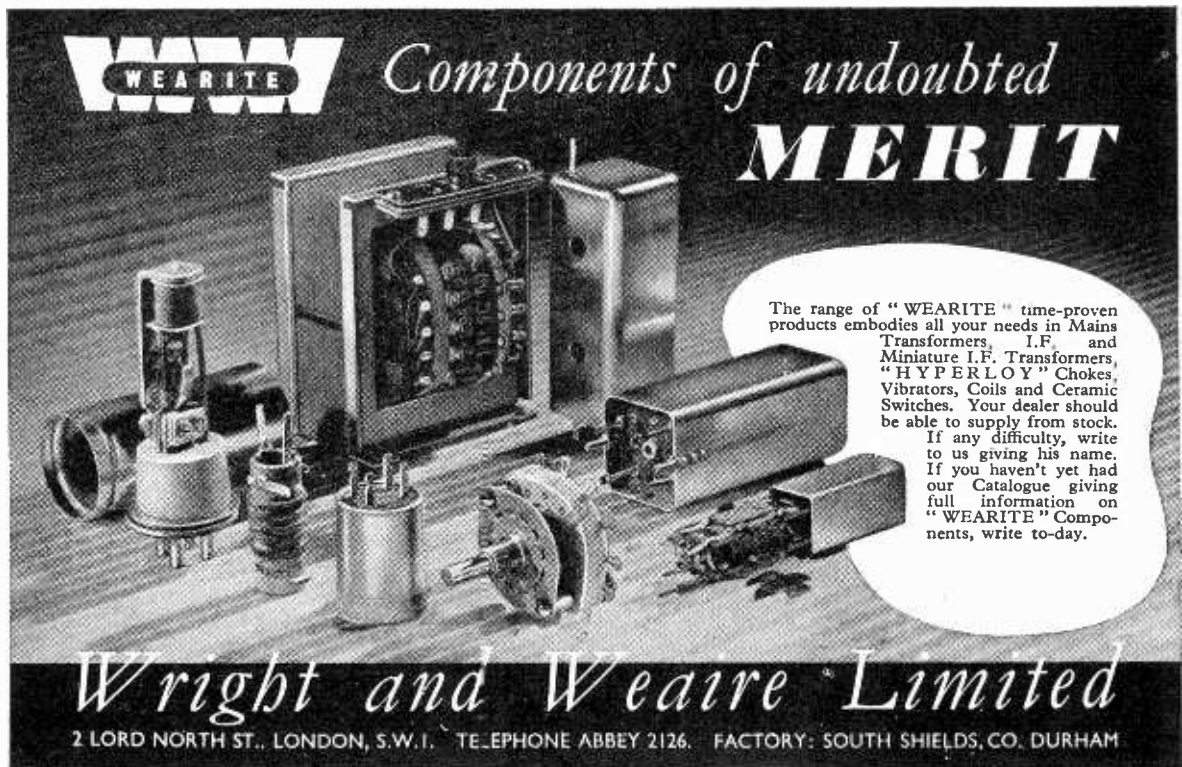

**WEARITE** Components of undoubted **MERIT**

The range of "WEARITE" time-proven products embodies all your needs in Mains Transformers, I.F. and Miniature I.F. Transformers, "HYPERLOY" Chokes, Vibrators, Coils and Ceramic Switches. Your dealer should be able to supply from stock. If any difficulty, write to us giving his name. If you haven't yet had our Catalogue giving full information on "WEARITE" Components, write to-day.

**Wright and Weaire Limited**  
2 LORD NORTH ST., LONDON, S.W.1. TELEPHONE ABBEY 2126. FACTORY: SOUTH SHIELDS, CO. DURHAM



# Valves and their applications

## EF42 AS TELEVISION FREQUENCY CHANGER

The constructional and electrical features of the E-F 42 described in the January and February issues of the "Wireless World"

show that it is a very versatile valve. Its high slope — nearly 10 mA/V — and low equivalent noise resistance — 750 ohms — make it suitable for many wide-band applications including R.F., I.F., and V.F. amplifiers. Its small size facilitates construction of compact circuits, and enables full advantage to be taken of recent developments in miniature components. Where it is desirable to economise in the number of valve types used, the versatility of the EF42 is of great value since it can be used as an amplifier, mixer and oscillator.

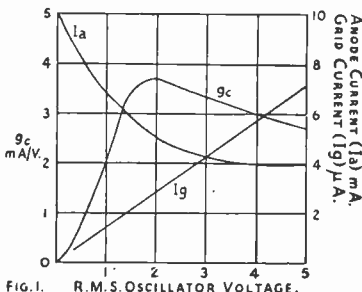

FIG. 1. R.M.S. OSCILLATOR VOLTAGE.

It is well known that a high slope pentode with a separate oscillator valve can be used successfully as a simple, high quality frequency changer with good stability and low noise level. A conversion slope ( $g_c$ ) of nearly 4 mA/V compared with 0.7 mA/V in a triode hexode is given by the EF42 with common grid injection of signal and oscillator voltages. Although this circuit requires two valves, its performance is much superior to that of a typical multigrid valve. The conversion gain is about six times as great and operation is more stable. Provided that the oscillator voltage is maintained above 2 V.r.m.s. the conversion gain is almost independent of its amplitude as shown in Fig. 1. The valve is also free from high frequency effects, such as control-grid current due to transit time, and will operate equally well with the oscillator frequency above or below the signal frequency. The valve noise is equivalent to a 3,500 ohm resistor in the grid circuit (15  $\mu$ V with 4 Mc/s bandwidth) and

compares very favourably with the 30,000 ohms to 200,000 ohms values for multigrid valves.

A 1 megohm grid leak resistor should be used to derive bias voltage and the oscillator drive adjusted to give 3  $\mu$ A grid current, i.e. 3 V bias. The valve can be protected against excessive cathode current in the event of failure of the oscillator by using a 56,000 ohms screen resistor.

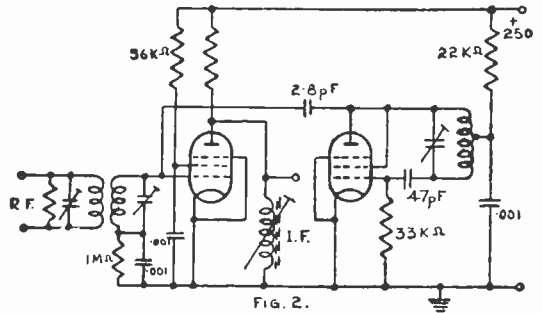

FIG. 2.

The EF42 is an efficient oscillator due to its high slope and may be triode connected for this purpose. It will oscillate with very low impedance circuits and a high tuning capacitance. Either series or parallel coupling of the oscillator voltage into the mixer grid circuit may be used. In series coupling, the primary of a transformer is coupled to the oscillator, the secondary is tuned with a high capacitance (150-250 pF.) and connected in series between the signal circuit and the mixer grid. Parallel coupling is a more simple arrangement since it requires only a small capacitance (2-8 pF.) between the oscillator anode and the mixer grid. This capacitance may be used to adjust the oscillator drive. A typical circuit is shown in Fig. 2. Total current consumption of both valves is about 15 mA.



Reprints of this report from the Mullard Electronic Research Laboratories can be obtained free of charge from the address below.

**MULLARD ELECTRONIC PRODUCTS LTD.,  
TECHNICAL PUBLICATIONS DEPARTMENT,  
CENTURY HOUSE, SHAFESBURY AVE., W.C.2**

(M.V.M. 67)

# Wireless World

RADIO AND ELECTRONICS

Vol. LIV. No. 7

July 1948

## Comments of the Month

**W**E suggested last month that the B.B.C., before committing itself irrevocably to a nation-wide F.M. broadcasting service, should set up an experimental A.M. service. Our plea was made largely on grounds of national economy; the present time seems inopportune for suggesting that listeners should provide themselves with expensive F.M. receivers on a large scale. Cheap sets could hardly be expected to retain their alignment sufficiently well for the advantages of F.M. to be realized.

There has been considerable support for our view, but one correspondent (whose letter is published elsewhere in this issue) protests that the use of V.H.F. adaptors with existing receivers would effectively damn an A.M. service on account of frequency drift. We think he overstates his case. The use of adaptors was not the central idea of our proposal, though these units would undoubtedly have some field of usefulness, and could be designed to work well in conjunction with suitable receivers. In any case, whether an adaptor be used or not, F.M. is much more adversely affected by frequency drift than is A.M. Nor can we agree that "A.M. is cheap and nasty." Except in the presence of certain kinds of noise there is no inherent difference between A.M. and F.M. in the matter of quality.

### Revolt Against Superlatives

**F**OR some time *Wireless World* has been in revolt against what we consider the indefensible practice of giving precise comparative significance to such vague superlatives as "super" and "ultra" in the official classification of frequency bands. This outmoded method—to which there is no parallel in any other branch of technology—has now been taken to even more absurd lengths by the Atlantic City Conference, which has agreed for international use on still another classification—"extremely high frequency"—for millimetre waves.

Our criticism of this deplorable method of classification is based, quite simply, on the fact that it does not work. Nobody—not even the defenders of the system—can ever remember the precise significance of "very," "ultra" and "super," etc. And, having assigned all the comparatives and superlatives in the English language to precisely delimited frequency bands, we have nothing left for use when we need to refer in a general way to all frequencies of, say, optical-range characteristics.

The existing state of confusion brought about by the "super system" is exemplified\* by two quotations from separate publications that have appeared during the past month:—

(a) V.H.F.—Very high frequency (or U.H.F., ultra high frequency). Alternating at a frequency higher than, say, 30 Mc/s.

(b) Apart from this, there has been a development of techniques enabling systems to operate at very high frequencies. (The term "very high frequencies" is used here in a general sense and does not refer specifically to the V.H.F. band).

We do not condemn the writers of these sentences. Though the definition (a) could hardly depart farther from the official interpretation, it does in fact give the reader a pretty good idea of the most widely accepted meaning of V.H.F. We like the "say." Similarly, the present system of classification imposed an obligation on the writer of (b) to use 21 words to explain an 18-word sentence; he had no other way of making it clear that he had in mind a vast but undefined range of the higher frequencies.

So far as *Wireless World* is concerned, we will try to avoid pestering our readers with "ultra," "super," and the rest of the family. Where it is necessary to refer in general terms to all frequencies above 30 Mc/s we will use for choice the term "extra high" (E.H.F.), but will use the official term "very high" (V.H.F.) in cases where it is clearly applicable to the 30-300 Mc/s band only.



Commenting in last month's editorial on the experimental F.M. service shortly to be launched by the B.B.C., "Wireless World" suggested that the ultimate success of F.M. broadcasting was closely linked with the problems of reception, and in particular with the problem of aligning domestic receivers—and keeping them aligned. This article suggests a possible way of minimizing that difficulty.

# Why Align Discriminators?

## Overcoming the Difficulties of Lining-up F.M. Sets

By THOMAS RODDAM

SOME time ago<sup>1</sup> I dealt with the design of a simple receiver for frequency modulation. In those articles the Foster-Seely discriminator was explained and the rules for designing such a discriminator, based on Sturley's *Wireless Engineer* paper,<sup>2</sup> were given. More recently<sup>3</sup> there has been an article on the ratio detector, which is rather a fashionable circuit now, especially as it is claimed that it does not need a limiter. Another circuit which has appeared in the patent literature is the locked-in oscillator. This circuit consists of an LC oscillator operating at the intermediate frequency and pulled into synchronism by the signal. The modulation appears in the anode circuit. There has been a lot of highbrow mathematics published about locked oscillators, and my personal advice to any reader who gets given the job of working with them is simple: it is: "Go on the land." I have had a locked oscillator running now for some months, but the reasons why it works with the particular component values used are absolutely unknown: it is required, in case anyone should point out the reports of Post Office work, to lock over a frequency range of  $\pm 10$  per cent, and must therefore be in a very non-linear mode.

All these circuits need careful lining-up if they are to be used as frequency-modulation detectors. The lining-up job is not a very difficult one if all the components have been adjusted to correct values by measurement on a bridge and if a good frequency-

modulated generator and cathode-ray oscilloscope are available. Even with these auxiliaries distortion measurement will sometimes give surprising results, because it is not easy to judge a straight line on the curved face of the oscilloscope. (It isn't easy to do the distortion measurement, either.) Even in these times of ever-growing wage packets, there are, I am told, a few individuals who, through extravagance in other directions, cannot provide

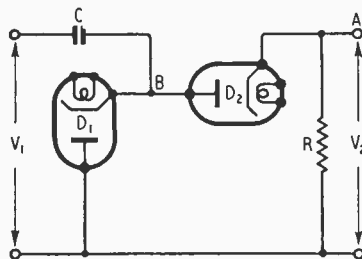

Fig. 1. Basic circuit of the diode counter discriminator.

themselves with a complete set of the test equipment needed. These shabby individuals may be interested in the simple discriminator circuit described in this article. It has, as an engineer of my acquaintance said of an induction motor, no moving parts. Consequently, it cannot be put out of adjustment and, once it is working properly, it will go on working properly for ever. It was first described as the discriminator in a monitor for use in F.M. transmitter stations, where it is essential to have a distortionless receiver if the transmitter distortion is to be measured.

This discriminator is not very efficient: it needs a good input,

and gives a small output. I do not regard that as a serious defect in a circuit which is built for experimental purposes. Saving one valve is all very well when you are building ten thousand sets, but usually the audio amplifier has some spare gain anyway, and even if it hasn't, I would rather add one stage and use a circuit which cannot go wrong. Insensitivity is not the only disadvantage: unless very special circuits are used, this discriminator operates at an intermediate frequency of about 150 kc/s. A more complicated circuit using cathode-follower drive could probably be operated at higher frequencies, but I should hesitate to try such a circuit without proper laboratory facilities, and then we are back in the professional class again. A frequency of 150 kc/s should not cause any real trouble, however, until several F.M. stations are operating. For the present 90.1-Mc/s B.B.C. transmissions a local oscillator operating on 44.975 Mc/s can be used to drive a triode mixer, with the advantage that although harmonic mixing is less efficient, the oscillator does not get out through the input circuits on to the aerial. After such a mixer a video amplifier designed to pass frequencies up to 300 kc/s can be used as an I.F. amplifier. A rough calculation suggests that a stage gain of at least 100 can be obtained, and it is, of course, advantageous to use a small amount of inductance to provide the best phase characteristic. The design of the video amplifier is rather outside my present scope, but it is not really very difficult. The alternative, which is more efficient, is to use a double frequency-change receiver, but as the first I.F. amplifier must be designed to have a good phase characteristic, and two oscillators

<sup>1</sup> *Wireless World*, April, June 1947.

<sup>2</sup> *Wireless Engineer*, February 1944.

<sup>3</sup> *Wireless World*, March 1948.

and two mixers are used, I am not sure that the design economy can be realized in practice. The choice is left to the reader, with my own personal recommendation to try the video amplifier circuit. Now for the discriminator itself.

The circuit is shown in Fig. 1. The input, which is limited, is applied at  $V_1$ . In Fig. 2 it is shown as a square wave of variable frequency. When the voltage is rising  $D_1$  is cut off, and  $D_2$  is conducting. The circuit CR then acts as a differentiating circuit and a pulse with a steep front and an exponential back appears across R. This is  $V_2$ . The back of the square wave, which is a negative-going voltage, causes  $D_1$  to conduct and  $D_2$  is cut off, so

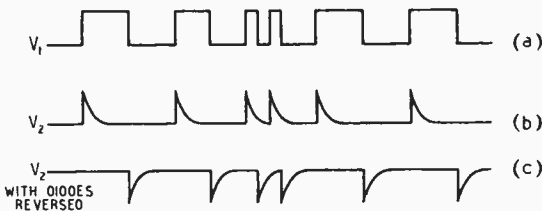

Fig. 2. Waveforms in the discriminator.

that nothing appears across R. The result is that the frequency-modulated square wave is converted into a train of frequency-modulated pulses, all of exactly the same size.

Each pulse actually consists of a sudden change in the number of electrons at A. In the circuit of Fig. 1 the electrons leave A and are replaced by the electrons which flow through  $D_1$  and R. If the diodes are both reversed, A goes negative, as shown in Fig. 2(c), due to a batch of electrons from the cathode of  $D_2$ . Those electrons then flow through R and back to B as emission from the cathode of  $D_1$ . A voltmeter across R will indicate the average number of surplus electrons at A (which may be negative, of course). The averaging time depends on the sort of voltmeter we use. A cathode-ray oscilloscope, for example, will average over a time of the order of perhaps  $10^{-8}$  second, a thermal instrument over a time of several seconds. By averaging over a time of the order of 20 microseconds we shall obtain a voltmeter reading which is propor-

tional to the number of electrons per pulse multiplied by the number of pulses in 20 microseconds. The number of electrons per pulse is constant, because each pulse is the same size, and the number of pulses in 20 microseconds is proportional to the input frequency. The voltmeter therefore gives a reading directly proportional to the input frequency. This, of course, is the audio modulation, for the square wave is simply a limited F.M. signal.

In practice all we have to do is to put a filter, with a cut-off at, say, 25 kc/s after the resistance R and apply the filter output to the audio amplifier. The filter should have fairly high attenuation

for the pulse frequency, so that the first audio stage does not receive large voltage peaks and get driven out of the linear region.

We can now do some rough calculations of the size of the components. The limiter is conveniently a pentode operated to below the knee of the characteristic. Using a 6AK5 (similar to CV138) an anode load of 20,000 ohms, with a screen resistor of 20,000 ohms fed from 150 volts, will give a good clean limiting characteristic. Most other R.F. pentodes can be used, with suitable values of anode and screen

negative, the anode rises to the full supply voltage: when it reaches about -1 volt, the anode is down to about +15 volts, and

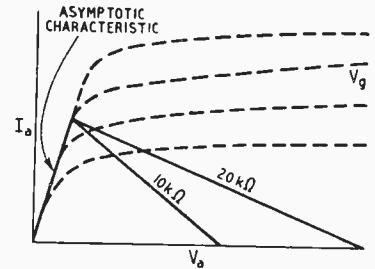

Fig. 3. Typical pentode characteristic showing load lines for good limiting.

does not drop any farther as the pulse frequency, so that the grid is driven to zero or positive bias. This sort of limiting gives much cleaner operation than grid limiting circuits.

If we take C in Fig. 1 as 80 pF, the total capacitance load on the limiter is about 100 pF. The limiter time constant is then 2 microseconds. For this work I take four time-constants as the total pulse length: with an exponential decay the voltage has then dropped to below 1 per cent of its initial value. This gives a pulse length of 8  $\mu$ sec. This 8  $\mu$ sec is actually the time of rise in Fig. 2(a), although the figure shows an almost instantaneous rise. With a 75-kc/s deviation, we should not allow the frequency to fall below, say, 50 kc/s, so that the highest frequency will be 200 kc/s. By reducing the capacitances to 50 pF, the "4 time constants" becomes 4  $\mu$ sec. Even this is

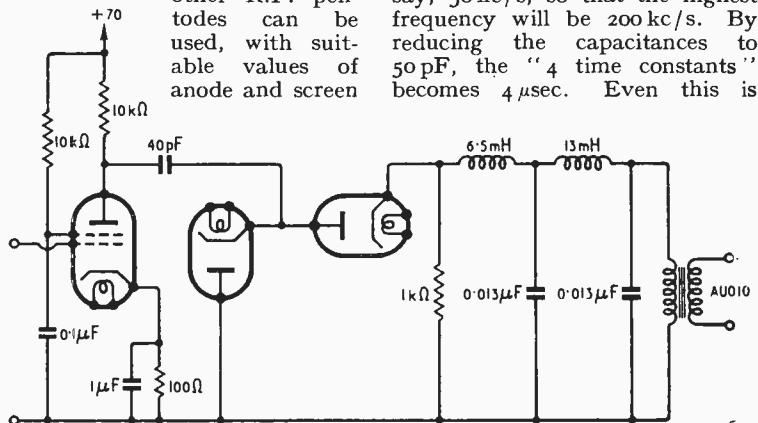
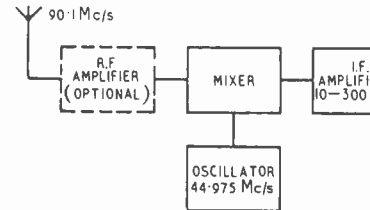

Fig. 4. Practical discriminator circuit, with values.

restors. Fig. 3 shows where the load line must lie to give good limiting. When the grid is driven

rather tight, and we will do better to reduce the anode voltage to about 70 and use a 10,000-ohm

**Why Align Discriminators?**— anode load. The value of  $R$  is made appreciably smaller, and the final values are shown in Fig. 4 and the block diagram of the set in Fig. 5. A convenient centre frequency for this circuit is 150 kc/s. With this frequency we can make a rough estimate of the output. Each pulse is triangular, lasting about



Apart from the inconvenience of the low intermediate frequency, which may turn out to be a blessing in disguise, the chief difficulty which may be experienced with this circuit is due to a failure to complete the D.C. restoring action through  $D_1$  before the next pulse arrives. The video amplifier must be carefully screened if high gains are needed. Both this amplifier

counter circuits, and I see no reason why germanium crystal diodes should not be used.

There are a number of possible modifications of this circuit. One is to use a blocking oscillator triggered by the voltage at A. This gives an enormously amplified output of the form 2(b), which can then be passed through a low-pass filter. It should be possible

Fig. 5. Block schematic diagram of complete receiver.

1 microsecond and of amplitude about 50 volts. The effective duty cycle is  $\frac{1}{2} \times \frac{1}{6.6} = 0.075$ , so that the output voltage will be 3.75. The available audio-frequency voltage will be of the order of 1 volt in a 1,000-ohm circuit, which can be stepped up to about 10 volts at a grid by means of a transformer.

and the limiter may develop parasitic oscillations: the limiter especially may need stopper resistors to avoid parasitics when the grid is driven positive. As a drive of about 5 volts R.M.S. is needed at the limiter grid, two stages of I.F. amplification should be enough for receivers in the primary service area. For the diodes I have used the 6AL5, which is a low-impedance miniature diode, but the 6H6 has been used quite a lot in

to eliminate the diodes and let the blocking oscillator act as its own D.C. restorer, using simply a differentiating circuit to trigger it. The circuit as described, however, is a safe and simple circuit, and it does seem to me to belong to a class which is only too often ignored nowadays. It does not cost more to test than the receiver itself costs. Those of us who are provided with all the facilities we need often forget that people do build sets at home and cannot carry out tests which we will cheerfully spend a week repeating.

## V.H.F. for Civil Aircraft

*Miniature Airborne Set and Ground Equipment with D.F. Facilities*

AS reported in our last issue, Ekco have produced a special lightweight radio telephone set for use in civil aircraft and they have also designed a complete ground station providing communications and D.F. facilities on extra-high frequencies. It is now possible to give some details of these equipments.

The aircraft set, which weighs 12 lb and measures 13 in  $\times$  6 in  $\times$  4½ in, operates from a 12-volt battery and takes 3.75 amps, or about the same consumption as a car radio set. Transmitter, receiver and a vibrator power supply unit are assembled on

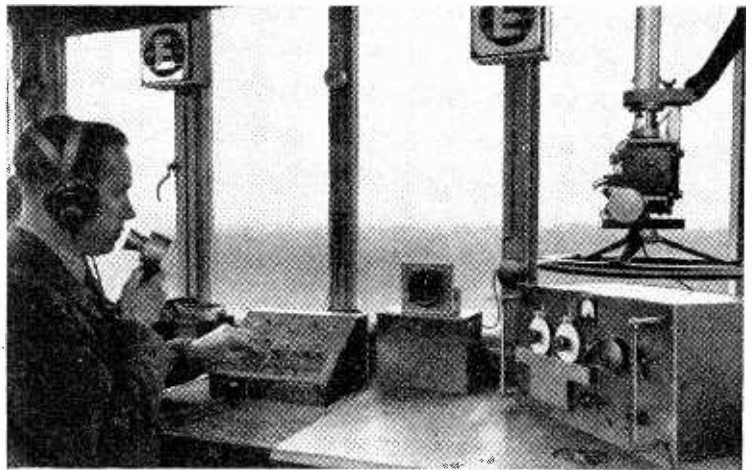

V.H.F. direction finder installed by E. K. Cole in the control tower at Southend airport. The aerial control wheel is visible on the right immediately above the D.F. receiver.

a single chassis and economy of space and parts is achieved by using some of its 17 valves (plus a rectifier) for both transmission and reception. It provides for operation on one or other of two channels, both crystal controlled and pre-set.

The set can be stowed in any convenient part of the aircraft as all switching operations, such as on-off, channel selection and send-receive, are confined to a tiny remote control unit measuring 1½ in  $\times$  2½ in  $\times$  4 in only. Provision is made



for two sets of headphones and microphones in the aircraft, throat-type microphones being used in order to leave the pilot's hands completely free, but any other pattern can be substituted if required.

One of the two channels is intended to be permanently set-up on

whole set is provided by a 12-volt vibrator and a full-wave valve rectifier.

For the airport control Ekco provides a neat rack-built installation comprising two separate transmitters and receivers with their power supplies. All four are crystal controlled and have provision for remote or local operation.

One transmitter and receiver is set up on the guard frequency, the other pair being on the airport frequency. This equipment is mains operated and each transmitter gives an aerial power of about 5 watts. Separate loudspeakers, also headphone and microphone sockets, are included, and this enables the guard channel always to be open for an incoming call. Separate aerials

are used for transmission and reception on each channel, four in all being provided.

At the Southend airport, where a set is in operation, the radio equipment is usually operated from the control tower where are fitted two loudspeakers, one always live to the guard frequency and the other for incoming calls on the airport frequency. Here also is installed a complete V.H.F. direction finder consisting of the same receiver as those used for communications but having a few modifications for D.F. operation. Bearings on aircraft can be made either by aural methods, using headphones and heterodyning the signal, or by a visual indicating meter. In addition to the vertical dipoles of the Adcock type D.F. aerial there is also a short vertical collector for sense determination, this is brought into use by a press-switch by the side of the D.F. receiver. A large hand-wheel (visible in the photograph of the D.F. equipment) serves for rotating the aerial, and its scale is marked off in degrees from true north and their reciprocals, which facilitates giving the aircraft a bearing to fly on in order to reach the airfield.

The D.F. and communication receivers are 15-valve superheterodynes with crystal-controlled oscillators, two R.F. and three I.F. stages on 9.7 Mc/s. Delayed and amplified A.G.C. is used, also a noise limiter and, as already mentioned, there is a B.F.O.

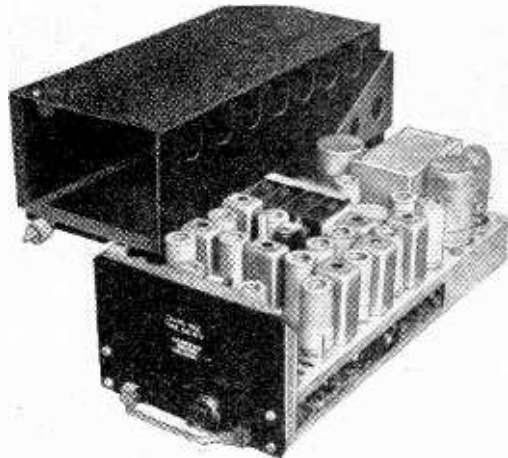

Ekco two-channel V.H.F. aircraft transmitter-receiver removed from its case.

the civil aviation guard frequency of 118.1 Mc/s, while the other will be set to the frequency allotted to the airport from which the locally owned aircraft usually operate, and will be within the band 118 to 128 Mc/s.

The design of the aircraft set is specially interesting as it comprises two crystal multiplier chains, two R.F. and frequency changer chains, a common I.F. amplifier with detector, A.G.C. and A.F. stages and a modulator chain.

Each crystal chain is used for both transmission and reception, the multiplier stages having band-pass couplings which cover the frequencies generated by both crystals. The receive crystal is 3.75 Mc/s higher in frequency than the send, this being the I.F. used.

Three stages of multiplication are used for transmission but two only for reception as the mixer grid serves also as a frequency doubler. Both crystal chains up to and including the mixer are the same and selection of one or the other is effected by a contact on the send-receive relay. Each chain also includes an R.F. power amplifier for transmission, the aerial being switched from one to the other by the channel selection relay. The R.F. stage is anode-modulated and delivers about 300 milli-watts to the aerial. The A.F. amplifiers can be used for intercommunication between pilot and passenger in the aircraft. High tension supply for the

## OUR COVER

The 15-ft scanner and drive mechanism for the radar equipment being installed at Liverpool by the Sperry Gyroscope Company is illustrated on our cover. It will be mounted on an 80-ft tower. The equipment, which is for the supervision of shipping along the 14-mile approach to the docks, provides a choice of displays of six different areas. The display units have been developed jointly by Sperry and Cossor.

Although the maximum range of this equipment is difficult to assess, two-way communication with an aircraft has been carried out up to 70 miles with the aircraft at 10,000 feet, while 33 miles has been covered at 2,000 feet.

The equipment is fully tropicalized to ensure satisfactory operation under extreme climatic conditions. The complete ground V.H.F. communication equipment costs £475, the D.F. apparatus £175, and the aircraft set £95 complete.

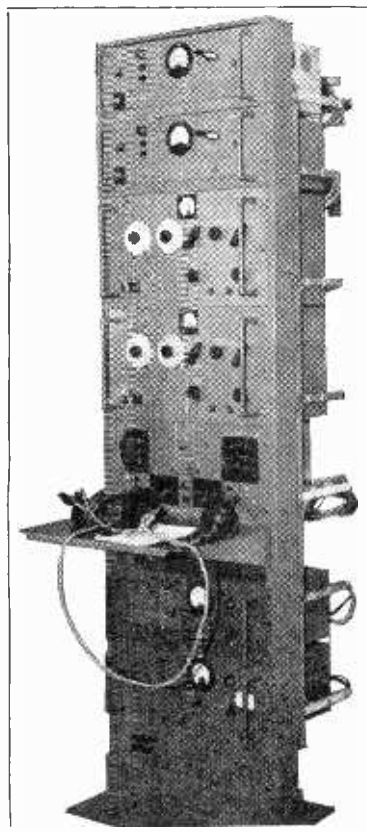

Ekco two-channel V.H.F. communications equipment for use at civil airports.

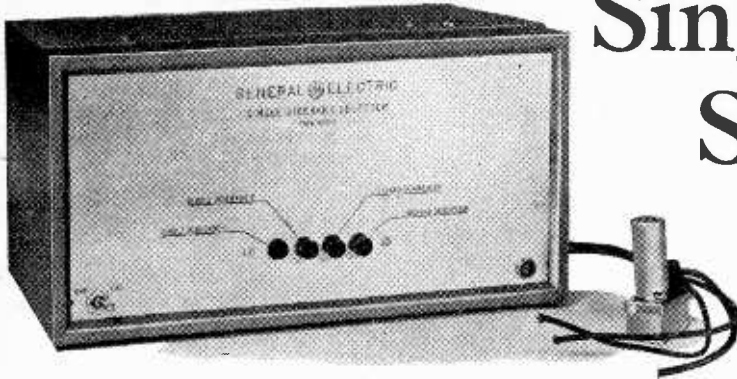

# Single Sideband Selector

By A. DINSDALE

Unit for Attachment to Communications Receivers

A SINGLE-SIDEBAND selector unit for attachment to communications receivers having an intermediate frequency

of approximately 455 kc/s has been developed by the General Electric Company of America. When properly connected and

aligned, this new unit permits single-sideband reception of either modulated or unmodulated (C.W.) signals.

In a crowded frequency band, heterodyne or sideband interference frequently affects only one sideband of the desired signal. By

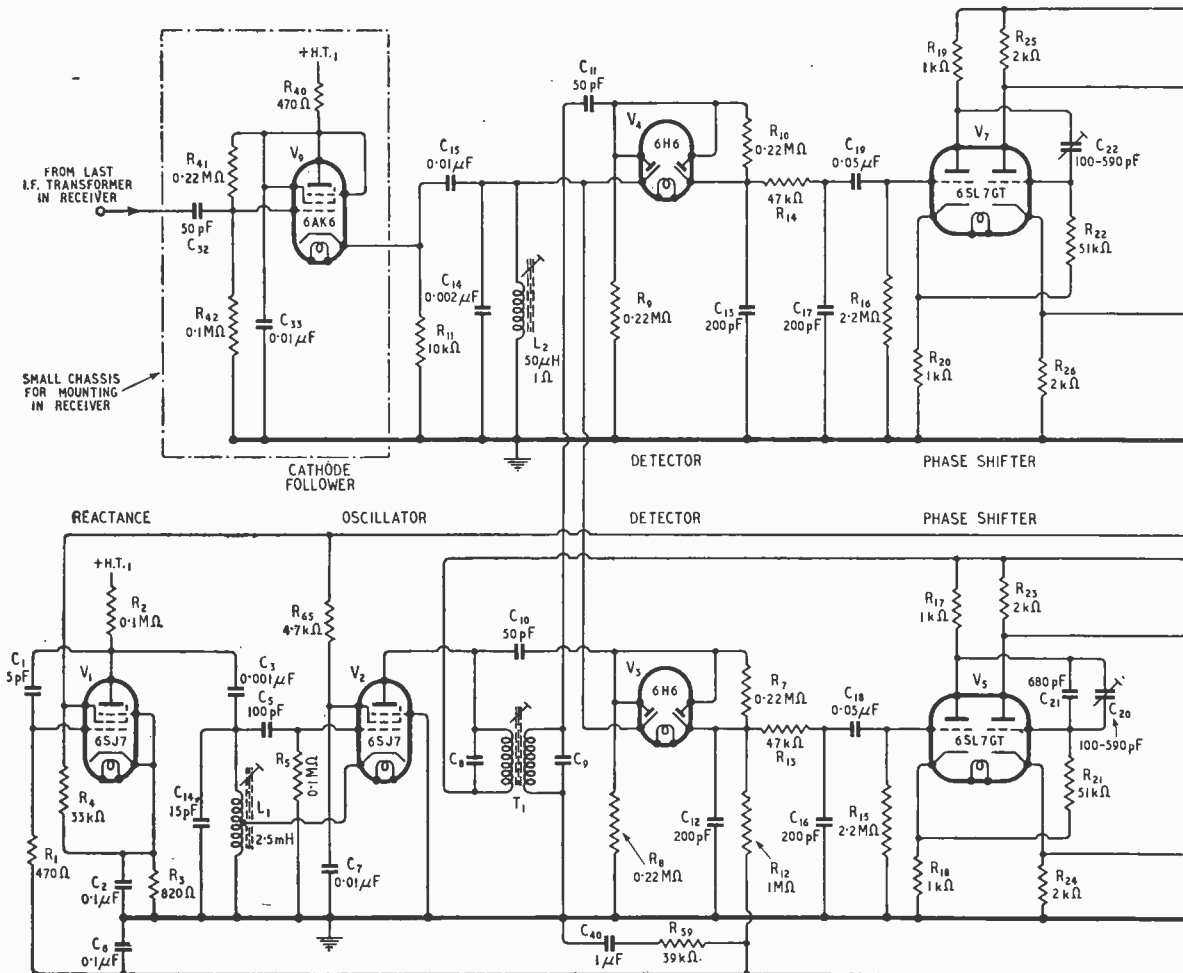



merely punching up push buttons on the front panel of the new unit, each sideband can be explored separately, the noisy one rejected, and the undisturbed one accepted.

By punching up a third button, double-sideband reception is achieved with a locally-reinforced carrier. This reduces distortion caused by selective fading. A fourth button disconnects the single-sideband selector unit and returns the system to normal reception.

The unit is illustrated in the accompanying photographs, and the circuit diagram supplies much technical information. As indicated in the circuit diagram, there are 14 valves, but essentially the unit comprises an oscillator, two detectors with accompanying phase-shifter circuits, and a single stage of A.F. amplification.

Briefly, signal voltage from the last I.F. stage of the receiver is fed into the selector unit, where detection and phase-shifting take

place, and the resultant audio voltage is then fed back into the input of the receiver's audio system.

Detailed installation instructions

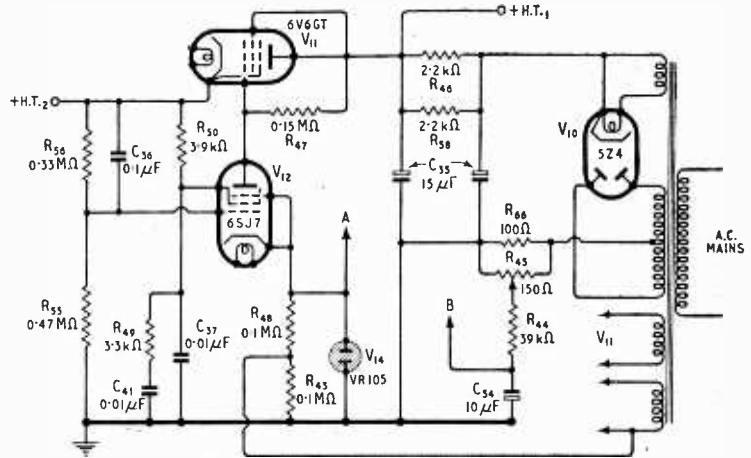

(Above) The stabilized power supply unit. (Left) The cathode-follower input stage is mounted in the receiver and feeds the I.F. signal to the detectors  $V_3$  and  $V_4$  through a low-impedance cable of 450pF capacitance. The oscillator  $V_2$  operates at the receiver intermediate frequency and is controlled within limits by the reactance valve  $V_1$ ; it is coupled to the detectors by  $T_1$  which is adjusted to give a 90-degree phase difference between its primary and secondary voltages. The detector outputs are passed through the phase-shifters which introduce a difference of phase between the signals of some 90 degrees over the range 70-7,000 c/s.

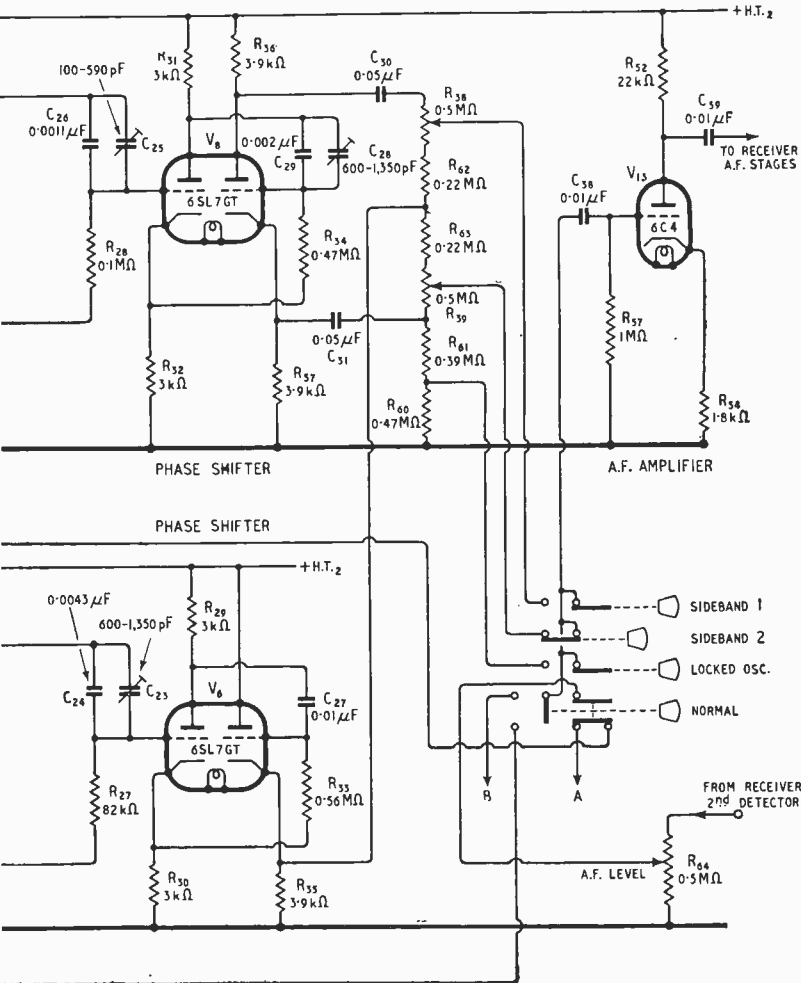

are supplied by the manufacturer for various makes of commercial communications receivers. Minor wiring changes must be made in most types of receiver, but these do not impair the normal operation or efficiency of the receiver.

The Single-Sideband Selector unit functions as a complete second detector and beat-frequency oscillator. Therefore, these circuits in the receiver are not used when the unit is employed in the 'Sideband' and 'Locked Oscillator' positions. Since the B.F.O. of the receiver is normally turned on and off from the front panel, it is not necessary to make changes in this circuit.

Although the receiver's second detector is not called upon to deliver audio voltage when the unit is used in the 'Sideband' or 'Locked Oscillator' positions, in some cases it does supply receiver

### Single Sideband Selector—

A.V.C. voltage and operate the S-meter, and these functions are not disturbed when the unit is connected.

In the 'Normal' position, the output of the receiver's second detector passes through one stage of A.F. amplification in the selector unit and is then fed back into the audio stages of the receiver. The connection between the receiver's second detector and audio system must therefore be broken; otherwise, audio output from the

is not critical. In the case of both connections, the braided shields of the cables should be grounded to the receiver chassis.

The manufacturer points out that the efficiency of the unit in rejecting unwanted sidebands and passing desired sidebands depends to a great extent upon the correct alignment of the I.F. circuits in the receiver. Therefore, if the alignment is doubtful, it is recommended that it be checked up. In any event, it is necessary to check the tuning of the secondary of the

Poor voltage regulation may cause the frequency of the oscillator to change with the setting of the manual R.F. gain control, or with A.V.C. action.

(3) Frequency modulation of the oscillator at mains frequency or harmonics.

Certain amounts of all three types of oscillator instability exist in the very best of equipment, but the manufacturer claims that this unit will work satisfactory with most receivers. In some instances, however, one or more of the three oscillator defects may be so severe as to render the unit useless for many purposes.

If the receiver itself is satisfactory, good operation may not be obtained when receiving certain stations whose frequency control systems suffer from excessive instability of the types listed above.

After the unit has been connected up to the receiver, the manufacturer's instructions list 14 steps which must be taken to complete the proper adjustments so that the unit will work properly with the particular receiver to which it is connected.

When the unit is used in any position other than 'Normal', a beat note will generally be heard as a signal is tuned in on the receiver. This beat is produced by the incoming carrier beating against the local oscillator in the unit. For A.M. reception, the receiver is tuned to zero beat.

In general, the mode of operation (i.e., Sideband 1, Sideband 2, Locked Oscillator or Normal) best suited to the occasion will depend to a great extent upon the degree of interference encountered.

When heterodyne interference is encountered on both sides of the desired carrier, the receiver's normal crystal-filter phasing adjustment can be used to minimize a strong heterodyne within the single sideband accepted for reception. This generally reduces audio fidelity, just as in normal receiver use.

It is recommended that the R.F. gain control on the receiver be kept as low as possible consistent with readability, to prevent overloading the receiver and the Selector Unit. The lower the signal input to the unit, the better the sideband rejection.

Reception of single-sideband suppressed carrier signals is per-

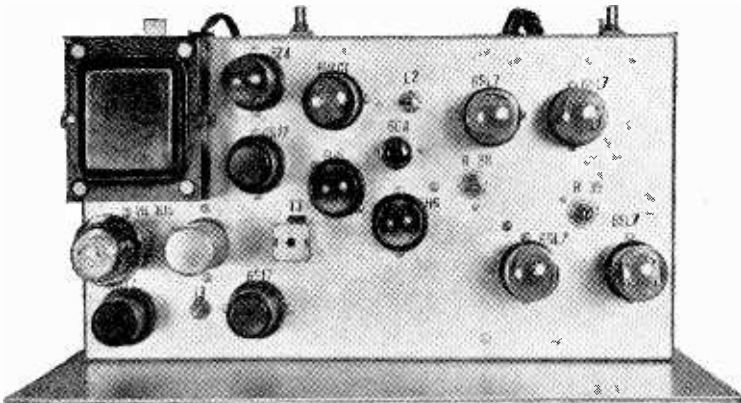

The interior of the Sideband Selector unit. The cathode-follower input stage is a separate unit fitted to the main receiver.

second detector will feed into the audio system at all times and render the selector unit useless.

Actual connection between the receiver and the selector unit is made by means of a tiny chassis containing a cathode-follower input stage, using a miniature valve. This chassis is installed in the receiver at a place convenient to the I.F. voltage point, so that the connecting co-axial lead can be cut as short as possible. Connection is made in this manner in order to minimize capacitive loading on the I.F. transformer secondary.

I.F. voltage for the cathode follower can usually be picked off most conveniently from the diode anode of the second detector, and in most cases this connection can be made from the top of the receiver chassis by means of a small lug attached to the proper pin of the second detector valve. The connection between the receiver's second detector and audio system can usually be broken most conveniently at the A.F. volume control. The length of the audio leads

last I.F. transformer and compensate, if necessary, for the additional capacitance introduced by the cathode-follower input stage.

It is also pointed out that satisfactory operation can be obtained only when the receiver to which the unit is attached is stable in its operating characteristics. The most troublesome source of instability in many receivers is the tunable oscillator which heterodynes the incoming signals to the intermediate frequency. Instability in this oscillator may fall into one or more of the following classifications:

(1) Moderately slow drift in frequency, usually stabilizing within two hours of operation. This drift is caused by temperature readjustment as the receiver warms up to stable operating temperature.

(2) Erratic jumps in frequency. This may be caused by line voltage changes, sudden release of stress due to thermal changes as the receiver warms up, poor sliding contacts on the oscillator tuning capacitor, or poor voltage regulation in the anode power supply.

fectly feasible with this unit. If the carrier is totally suppressed, the local oscillator of the Selector Unit has no incoming voltage on which to lock, but it will operate to provide good single-sideband reception. With a transmitter carrier attenuation of, say, 20 db, however, sufficient carrier voltage will be fed into the unit to enable the local oscillator to lock-in automatically at the correct frequency.

When receiving single-sideband transmissions, the operator is warned to make certain that the unit is set to receive the sideband being transmitted. The A.V.C. switch of the receiver should be off for this type of reception.

For C.W. reception, the receiver B.F.O. should be switched off when the Selector Unit is used in the 'Sideband' or 'Locked Oscillator' positions. The local oscillator in the unit serves as a B.F.O. But if the unit is switched to 'Normal' the local oscillator is switched off, and the receiver B.F.O. must be switched on.

As in the case of A.M. signals,

the method of operation for C.W. will depend upon conditions. If interference is encountered, try one sideband or the other. The advantage of this unit over a crystal filter is that an entire sideband of interference is eliminated, rather than a small 'notch.' Furthermore, removal of such interference is automatic because critical phasing controls are not involved. 'Chirpy' C.W. signals can be copied on this unit, whereas the crystal filter makes this difficult or impossible.

Incidentally, C.W. reception should not be attempted with the receiver set to the 'sharp' crystal position, and the Selector Unit set to one sideband. Since the receiver must be detuned to produce an audible beat note, the incoming signal will likewise be detuned off the peak of the crystal-filter response curve, and hence the signal will be greatly attenuated.

In the 'Locked Oscillator' position, the only difference between this type of reception and that afforded by a conventional

receiver is that the incoming carrier is built up or 'exalted' by the local oscillator in the Selector Unit. 'Exalted' or 'Locked Oscillator' reception reduces distortion effects brought about by selective fading on high frequencies, or by severe heterodyne interference. By thus building up the carrier locally, fading will then only slightly increase the effective depth of modulation, since, in most cases, the amplitude of the local oscillator is ten to thirty times as great as the amplitude of the received carrier.

As at present designed, the Single-Sideband Selector unit is intended for the use of military services, communication companies, and amateurs. The engineers who developed the unit feel that eventually the principles involved will be incorporated in future communications receivers. It is possible, also, that some modification may be developed for use in broadcast receivers in regions where station separation is inadequate.

## Manufacturers' Products

### Electric Soldering Gun

**I**N this soldering tool the copper bit, which consists of a hairpin-shaped wire, is heated by current from the secondary winding on a

small transformer housed in the body of the tool. A very heavy current at a fraction of a volt is needed and as a consequence the wire bit heats up very quickly. Seven seconds only is the time claimed by the makers and this is fully substantiated by a practical test.

As this current is taken intermittently the average consumption over a period is extremely small. The tool will solder any joint capable of being dealt with by the ordinary domestic type. Its great advantage is that it is available for immediate use at all times, if one may regard seven seconds as a negligible space of time.

The makers are the Burgoyne Engineering Co., Ltd., Robert Street, Hampstead Road, London, N.W.1, and the price is £3 19s 6d.



Burgoyne seven-second electric soldering gun.

As current is consumed only during the actual process of soldering, the "on-off" control is in the form of a press switch in the handle grip. Measurements show that the primary consumption on A.C. mains of 230 volts is 0.45A, or 104 watts, but

### Multi-ratio Output Transformer

**A** NEW high-grade multi-ratio output transformer is now obtainable from M.R. Supplies Ltd., 68, New Oxford Street, London, W.C.1. It is wound on a core measuring 4½ in x 5½ in x 1½ in, securely clamped between cast end-plates to prevent "chatter" when handling high power.

The secondary is wound in four sections sandwiched with the prin-

ary and electrostatically shielded. Each section is joined to a separate pair of terminals and by a combination of series and parallel connections output ratios of 18, 24, 36 and 72 to 1 are available.

The primary is centre-tapped and there is no air gap in the core as the transformer is intended to be used mainly in push-pull circuits. Under these conditions it is rated to handle 20 watts with a substantially level output from 30 to 20,000 c/s.

This transformer is listed as the model MR/448 and the price is 75s.

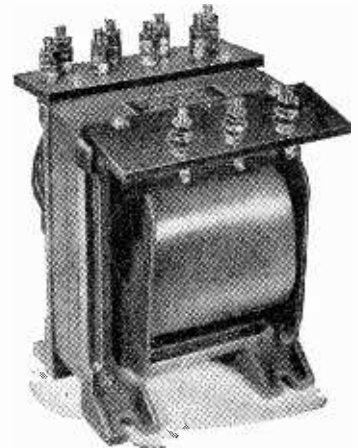

M.R. Supplies 20-watt high-fidelity output transformer giving choice of four ratios.



# Gas Molecules as Resonators

## Frequency Stabilization at E.H.F.

### Using Absorption Spectra

WHEN microwaves of the order of 1 cm (30,000 Mc/s) are passed through certain gases, energy is absorbed at well-defined frequencies, due to the excitation of various modes of vibration in the gas molecules themselves. One of the most clearly defined absorption lines is in ammonia gas, at a frequency of 23,870.1 Mc/s, and this has been successfully used as a frequency control for an oscillator giving stability of the order of 1 part per million.\*

The beauty of the system is that, unlike a quartz crystal resonator, the mid-frequency of the absorption band in a gas is independent of temperature and pressure, and no thermostatic control is required. The frequency is affected by magnetic and electric fields, but variations due to the earth's magnetic field are negligible, and inside the waveguide or cavity resonator, which is normally used to excite resonance in the gas, the gas will be screened from external electric fields.

The width of the absorption band decreases, and the effective  $Q$  of the gas as a resonator increases as the pressure and temperature are reduced. The spread of the response curve due to intermolecular collisions can be reduced by lowering the gas pressure to the point at which the mean free path of the molecules is comparable with the dimensions of the container. Still lower pressures merely reduce the number of molecules present, and so decrease the absorption coefficient. Temperature affects the bandwidth by changing the velocity of thermal agitation of the molecules and so calling for a different range of frequencies for excitation; it will be appreciated that a molecule travelling in the same

direction as the field in the waveguide will, because of the Doppler effect, require a slight increase of frequency at the source before the apparent frequency, as "felt" by the molecule, reaches its critical resonant frequency. A lowering of the source frequency will be necessary when the molecules are travelling against the motion of the field.

In a practical case a waveguide 0.43 in  $\times$  0.18 in and 12 ft long was used, and with a gas pressure of 0.01 mm/Hg a loss of 13 per cent in power was obtained at the principal absorption line in ammonia, the resonant  $Q$  being of the order of 100,000. Direct control of an oscillator, say, a klystron, at this frequency, in the manner of a quartz crystal, is impracticable except with small fixed loads, owing to the difficulty of providing suitable buffer amplifiers. With normal and vari-

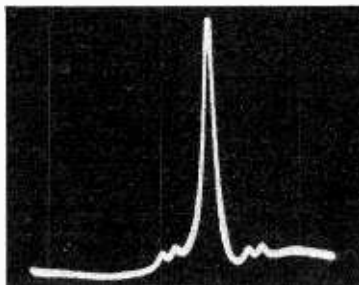

Courtesy: "R.C.A. Review"

Absorption line of ammonia at 23,870.1 Mc/s. The horizontal length of the trace is approximately equivalent to 14 Mc/s.

able loads the method adopted was to compare the oscillator frequency with the absorption line in the gas by a variable oscillator arranged to sweep cyclically a narrow band centring on the absorption line. Pulses are generated as the variable frequency sweeps through the absorption line, and again as zero beat with the oscillator under control is passed. After converting the frequency-modulated beat to ampli-

tude modulation, the pulses are passed to a phase detector where they are differentiated and limited to ensure that the mid-point of each pulse is clearly defined. At coincidence there is no output from the detector but deviation on either side produces a voltage which, when applied to the reflector plate of the klystron, tends to remove the error in frequency.

The paper referred to discusses the advantages and limitations of this sampling method of frequency regulation, and also shows the absorption spectra of the gases which might be usefully employed to stabilize "spot" frequencies in the range 20-25 kMc/s. An "atomic clock" controlled by absorption resonance is envisaged.

## NEW BOOK

**Television Simply Explained.** By R. W. Hallows. Pp. 198 with 112 illustrations. Chapman & Hall, Ltd., 37, Essex Street, London, W.C.2. Price 9s 6d.

IN his preface the author states his aim in the following words: "I have tried to explain a difficult subject in such a way that readers with no previous knowledge of electricity may form a clear picture in broad outline of television as it is to-day." In this he has very largely succeeded, and while one may be doubtful if the complete ignoramus would really gain any understanding of television, it is certainly true to say that the book does give quite a detailed account of television in very simple language. Moreover, this detailed account is reached in very easy stages and unfamiliar terms are explained as they are introduced.

The author uses sound to explain the idea of vibrations and frequency and then goes on to show how sound broadcasting is carried out. Using this as a basis, the transmission of still pictures is dealt with as a link in the chain of his argument to the fundamental ideas of television. This takes about one-third of the book and television proper is then treated. Starting with mechanical systems as the least complex, the progression to cathode-ray apparatus is simple and straightforward.

The book is an exceedingly good introduction to television. It is much more suited to those knowing but little of wireless in any of its forms than to those who are familiar with wireless technique but lack a knowledge of the television branch.

W. T. C.

\* "Frequency Stabilization with Microwave Spectral Lines," by W. D. Herschberger and L. E. Norton, *R.C.A. Review*, March, 1948.

# Be Service wise —★BRIMARIZE!

TYPE 41 is an output pentode, very popular in pre-war car radio receivers. Where space permits, type 42 will make a good replacement and in 6-volt receivers, no circuit changes will be required. If the larger bulb size cannot be accommodated, type 6V6GT must be employed, but this will involve a change of socket. In 12-volt receivers where the heater of the 41 is connected in series with one of the other valves, a balancing resistor must be fitted to compensate for the higher heater currents of types 42 and 6V6GT.

PUNCH HOLES HERE

		CHARACTERISTICS		
		Type 41	Type 42	Type 6V6GT*
	Types 41 and 42	Heater Voltage 6.3	6.3	6.3 volts
	Type 6V6GT	Heater Current 0.4	0.7	0.45 amp
		Anode Voltage 250	250	250 volts
		Anode Current 32	34	32 mA
		Bias Resistor 500	410	390 ohms
		Optimum Load 7500	7000	7500 ohms
		Power Output 3.2	3.2	3.3 watts

\*These conditions of operation have been selected so as to ensure minimum circuit changes.

TYPE	CHANGE SOCKET		CHANGE CONNECTIONS		OTHER WORK NECESSARY
	FROM	TO	FROM OLD SOCKET	TO NEW SOCKET	
42	U.X. 6 PIN NO CHANGE		NO CHANGE		6-volt receivers—no change. 12-volt receivers—fit balancing resistor to preserve the rated voltage across each valve heater. This is particularly important when type 42 is employed.
6V6GT	U.X. 6 Pin	Int. Octal	Pin No. 1 " 2 " 3 " 4 " 5 " 6	Pin No. 2 " 3 " 4 " 5 " 8 " 7	

★ BRIMARIZING ... A scheme devised by BRIMAR for keeping repair lines on the move, a means whereby radio sets may be kept working happily in the home and not waiting on the shelf.

## BRIMAR

### RADIO VALVES

STANDARD TELEPHONES AND CABLES LIMITED, FOOTSCRAY, SIDCUP, KENT.

A SERVICE PLAN FOR PLANNED SERVICE

Punch holes where indicated, cut away this portion and file

16

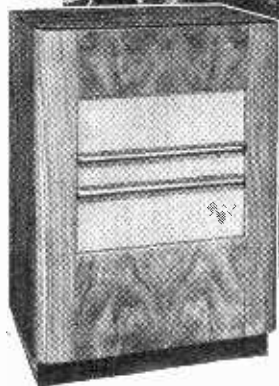

**CONSOLE  
REPRODUCER MODEL KC10**

Designed for better listening in the home, the KC10 Console Reproducer incorporates the K12/10 12 in. moving coil loudspeaker in an acoustically damped, totally enclosed, cabinet of optimum dimensions. The walnut veneered cabinet is hand polished and fitted with an anodised aluminium grille. PRICE 20 Gns.

# ELIMINATE SOUND DISTORTION

Can distortion be eliminated? Not quite, of course, but it can be reduced to a minimum by the use of loudspeakers which will introduce as little discoloration as possible—well designed loudspeakers—Vitavox loudspeakers in fact.

## VITAVOX

**MANUFACTURERS OF SOUND EQUIPMENT**

VITAVOX LIMITED  
Westmoreland Road, London, N.W.9.  
Grams: Vitavox, London, England

# Vortexion

## C.P.20A 15 WATT AMPLIFIER

For 12 volt battery and A.C. Mains operation. This improved version has switch change-over from A.C. to D.C. and "stand by" positions and only consumes 5½ amperes from 12 volt battery. Fitted mu-metal shielded microphone transformer for 15 ohm microphone, and provision for crystal or moving iron pick-up with tone control for bass and top and outputs for 7.5 and 15 ohms. Complete in steel case with valves.

As illustrated. Price £28 0 0

## A.D. 47 10-valve Triode Cathode Follower AMPLIFIER

For this recording and play-back amplifier we claim an overall distortion of only 0.01% as measured on a distortion factor meter at middle frequencies for a 10 watt output. The output transformer can be switched from 15 ohms to 2,000 ohms, for recording purposes, the measured damping factor being 40times in each case. Full details on request.

- "SUPER FIFTY WATT" AMPLIFIER complete in case. Price 36½ Gns.
- RECORD REPRODUCER AMPLIFIER complete in case. Price 25½ Gns.
- "THIRTY WATT" AMPLIFIER complete in case. Price 30½ Gns.



**EXPORT  
ENQUIRIES  
INVITED**

# VORTEXION LTD.

Telephones: LIBerty 2814 and 6242/3

**257-261 THE BROADWAY,  
WIMBLEDON, S.W.19**

Telegrams: VORTEXION, WIMBLE, LONDON



# Electronic Circuitry

## Selections from a Designer's Notebook

By J. McG. SOWERBY

(Cinema Television Ltd.)

*In this new regular feature we hope to bring to the notice of readers recent developments in circuit technique which may have applications in electronic arts other than those directly concerned with communications.*

**The Cascode Amplifier**—Although the useful so-called "cascode" amplifier circuit is at least ten years old<sup>1</sup>, it does not seem

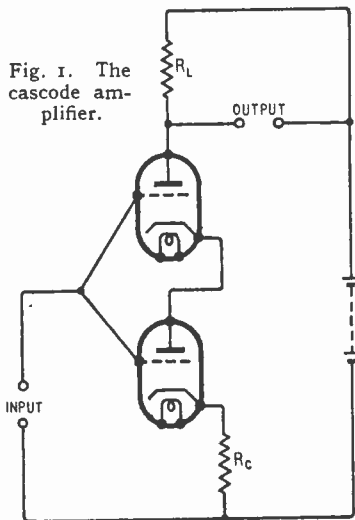

Fig. 1. The cascode amplifier.

to be at all widely known. Fundamentally it consists of two triodes arranged in series as shown in Fig. 1. It will be seen that the two valves, or two halves of a double triode, appear as a single triode of new characteristics as far as the external circuit is concerned. These characteristics enable a high gain to be obtained at low frequencies.

If the circuit is analysed, one finds that the equivalent single triode has an apparent amplification factor  $\mu_e = \mu^2 + 2\mu$  where the two actual triodes are similar and each of amplification factor  $\mu$ , and an apparent internal resistance  $R_{ae} = \mu R_a + 2R_a$  where  $R_a$  is the anode resistance of one actual triode. It follows that the apparent mutual conductance is  $\mu_e/R_{ae} = g_m$  where  $g_m$  is the mutual conductance of one actual triode.

We see at once that a large value of  $\mu_e$  will be obtained with quite ordinary triodes, but that to achieve a correspondingly large resistance will have to be used because  $R_{ae}$  will also be abnormally great. An example will show the magnitudes of the quantities involved. If  $\mu = 32$  and  $R_a = 50 \text{ k}\Omega$ ; then  $\mu_e = 1100$  nearly, and  $R_{ae} = 1.7 \text{ M}\Omega$ . If we now make  $R_L = 1 \text{ M}\Omega$ , and  $R_c = 500 \Omega$ , we find the gain to be nearly 340, which is fairly typical.

The cascode amplifier is not very suitable for audio work, owing to the high impedances involved. It finds its principal applications in D.C. amplifiers where only very low frequencies are involved, and in the amplifier sections of voltage stabilizers.

When using this circuit grid current is often encountered at anode currents of even a fraction of a milliampere. This difficulty can often be overcome by the provision of a few volts of positive bias for the upper valve. This modification is embodied in the typical series voltage stabilizer

of Fig. 2, illustrating the use of the cascode amplifier. Here, the maximum gain is not achieved because the lower triode receives less input than the upper. The loss in gain is not great however.

**Cathode-Coupled Multivibrator**—Readers will be familiar with the ordinary multivibrator—due to Abraham and Bloch—consisting of two triodes with resistance loads, each anode being connected to the other's grid through an RC coupling. This is a useful and widely known device for generating a roughly square waveform. A variant of the circuit uses two pentodes or tetrodes, and the consequent absence of Miller effect enables the change-over time to be materially reduced. However, whichever circuit is used, it is not always easy simultaneously to produce unity mark/space ratio and an output waveform rectangular within a few per cent, together with a simple means of variation of frequency.

Recently<sup>2</sup> a relatively novel

<sup>1</sup> Pullen, K. A. *Proc. I.R.E.* Vol. 34. No. 6. p. 402 (June 1916).

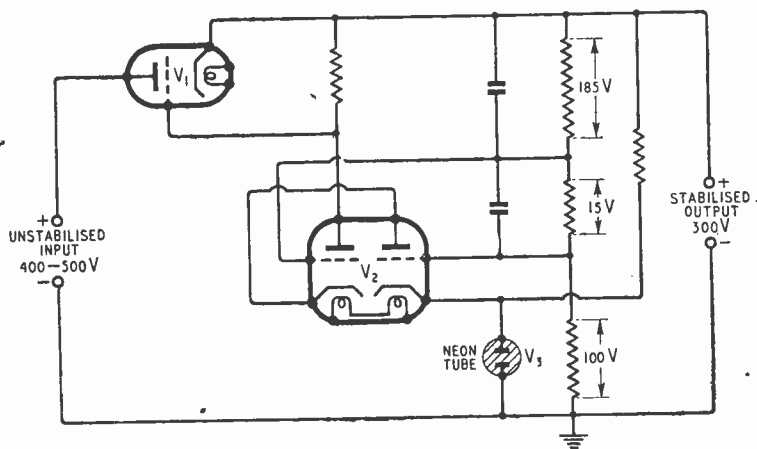

Fig. 2. Typical series stabilizer with cascode amplifier ( $V_2$ ).

<sup>2</sup> Hunt, F. V. and Hickman, R. W. *Rev. Sci. Inst.* Vol. 10. No. 1. p. 6. (Jan., 1939).

**Electronic Circuitry—**

type of multivibrator has made its appearance which, when provided with the rather obvious modifica-

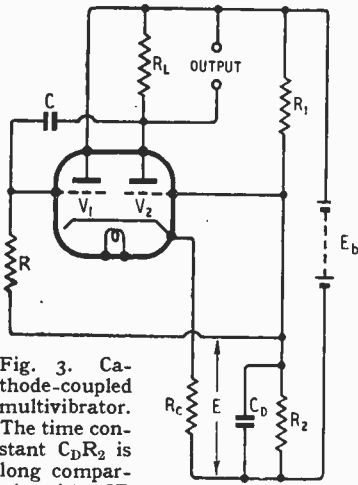

Fig. 3. Cathode-coupled multivibrator. The time constant  $C_D R_2$  is long compared with  $CR$  and  $R_2 \ll R$ .

tion of positive bias, can meet the requirements outlined above. The circuit of this multivibrator is shown in Fig. 3, and its mode of operation is as follows. When first switched on the two valves take about the same anode current, since they have the same bias. Suppose now that some small disturbance occurs in the circuit tending to make the grid of  $V_1$  negative. The current in  $V_1$  falls and, because of the common cathode resistance  $R_c$ , the current in  $V_2$  rises so that its anode moves negatively. The anode of  $V_2$  is coupled back to the grid of  $V_1$  through  $C$  so that the action is cumulative and  $V_1$  is abruptly cut off.  $V_1$  remains cut off while  $C$  discharges through  $R$  and  $R_L$  in series, and eventually  $V_1$  begins to conduct again. It is easy to see that the process is reversed, and  $V_2$  is cut off while the grid of  $V_1$  is held positive for a period determined by  $(R + R_L)$  and  $C$ . Provided that  $V_1$  passes no grid current during the positive excursion of its grid, it is obvious that  $C$  is charged and discharged symmetrically so that unity mark/space ratio is assured.

In order to ensure that  $V_1$  shall take no grid current,  $R_c$  must be made sufficiently large

so that when  $V_1$  has an anode voltage of  $E_a = E_b - E(1 + R_L/R_c)$  approx. it will pass an anode current

$$I_a = (1 + R_L/R_c) \frac{E}{R_c} \text{ approx.}$$

at a negative grid bias of more than one volt as determined from the valve curves. When designing, it is generally (but not always) convenient to make  $E$  equal to the peak-to-peak output voltage across  $R_L$ , but in any case  $E$  should be at least five times the grid base of the valve.

The output waveform is nearly flat-topped—it would be exactly flat-topped but for the current through  $RC$ . The best approach to "flat-toppedness" is obtained when  $R$  is very large compared with  $R_L$ , and what we may loosely call the "deviation from flat-toppedness" is about  $100R_L/R$  per cent. Hence if  $R_L$  is 5000 ohms and  $R$  is one megohm the output will be flat-topped within about  $\frac{1}{2}$  per cent—which is good enough for most purposes.

The frequency of the oscillation—whose amplitude is about  $ER_L/R_c$  peak-to-peak across  $R_L$ —is approximately given by

$$f_o = \frac{1}{4.6C(R + R_L) [\log(ER_L/R_c) - \log(E_{gb})]}$$

where  $E_{gb}$  is the grid base of the valve under the working conditions, and this frequency may be varied by adjustment of either  $R$  or  $C$ . If possible it is better to vary  $C$  because this leaves the shape of the output waveform relatively unaffected.

If desired an additional load may be placed in the anode of  $V_1$ . The output obtained therefrom will be out of phase with the output from  $V_2$ , and it will not be square. The positive peak will be flat-topped but the negative peak will have part of an exponential waveform superimposed on the flat top. The introduction of a load on  $V_1$  will also introduce Miller effect into  $V_1$ , so that in this case pentodes should be used.

On the whole this circuit represents a very convenient and simple means of generating square waves of variable frequency and good waveform for amplifier testing, etc.

**"Radio Laboratory Handbook"**

A new (4th) edition of this popular book by M. G. Scroggie has just been issued by our Publishers. It has been revised and extended to include V. H. F. technique. Price 12/6; by post 12/11.

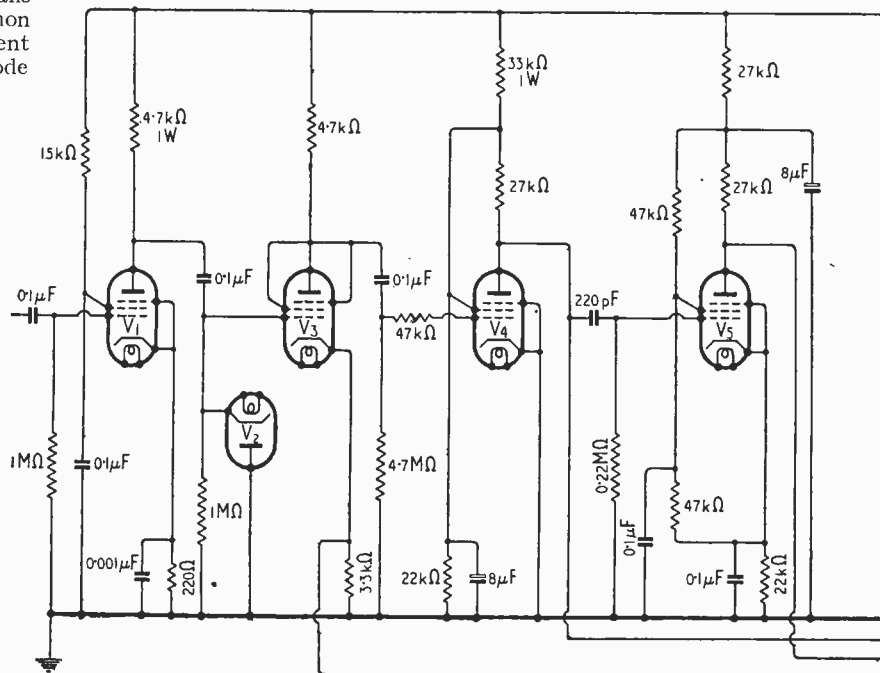

# “Surplus” Television Receiver

## Simple Set with Electrostatic Deflection

By L. J. DALBY, B.Sc.

THIS article describes very briefly the circuit of a television receiver which, though very simple and inexpensive, is yet capable of giving good results. The heart of the set is a cathode-ray tube readily obtainable from war-surplus equipment. The tube, of a type used in many radar display units, is of 6-in diameter with electrostatic deflection: the type number is VCR97. The screen is green, but against that slight disadvantage is the great attraction of cheapness. The picture brightness, of course, is not equal to that of the usual electromagnetic television tube, but it is adequate if light is not allowed to fall directly upon the screen.

In spite of the economies that have been effected, the performance leaves little to be desired. The set is being operated at a distance of 100 miles from Alexandra Palace, and even at that

range provides a picture when propagation conditions are good enough to give a field strength better than 50  $\mu\text{V}/\text{m}$ .

The complete circuit of the video, sync separator and time base portions of the set is given in the diagram. With the exception of  $V_2$ , which is an ordinary diode, all valves are of types also obtainable as surplus, either VR91 (EF50) or VR65 (SP61).

The sync separator is almost identical with that described by W. T. Cocking in *Wireless World* for March, April and May 1947, the only difference being that for  $V_5$  a VR91 is used to reduce the number of valve types; also the frame sync is derived as a voltage pulse across the anode load of this valve.

The time bases (line  $V_6$ , frame  $V_8$ ) are transitrons (see *Wireless*

*World*, June 1946) arranged to give large amplitude sawteeth. The second valve of each pair is a simple paraphase valve giving a sawtooth of approximately equal amplitude but opposite phase to that of the transitron. The sweep amplitudes can be adjusted by varying the 500-volt supplies to each pair of valves. It should be noted that on account of the high anode loads of the transitrons, which are necessary to secure adequate outputs, the fly-back times are on the long side, but not seriously so. The shift system is simple and is used to compensate for imperfections in the tube gun and plate assembly.

The video amplifier  $V_1$  is arranged to work with an input of 3-5 volts amplitude of negative-going signal. The C.R. tube grid is fed from the cathode of  $V_2$ , which is a cathode follower.  $V_2$  is a D.C. restoring diode. The sync

Circuit of the V.F., sync separator and time bases of the modified radar unit.

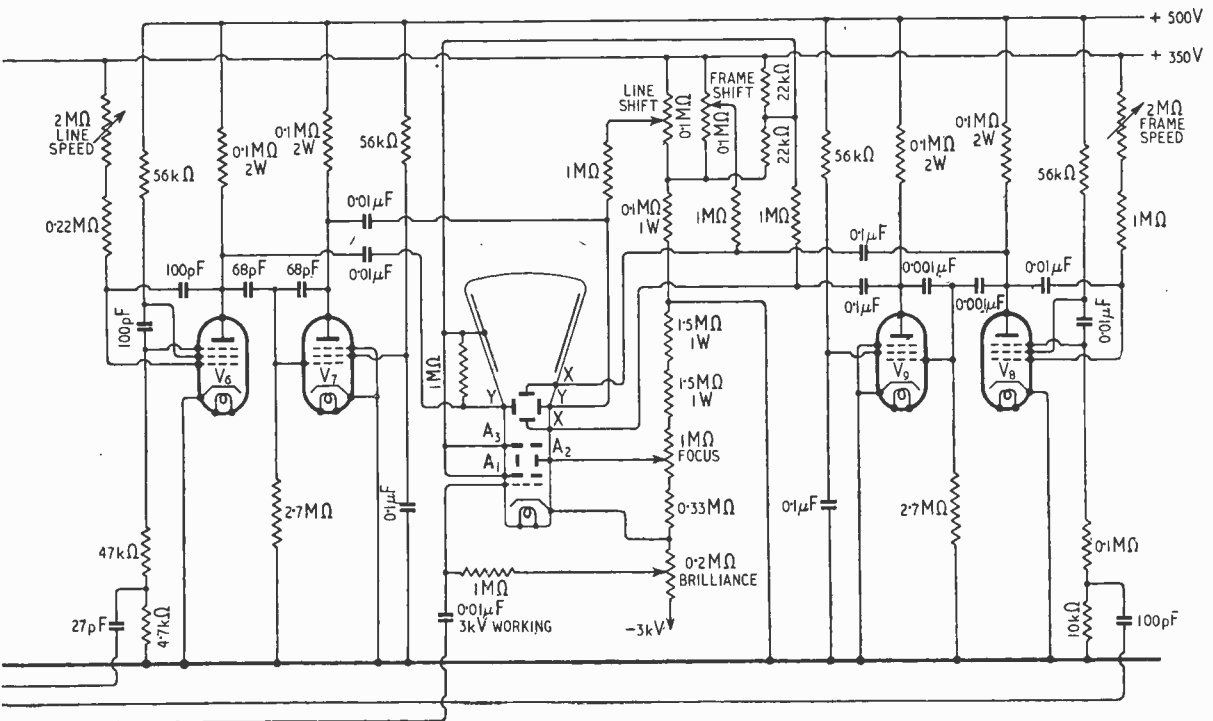



"Surplus" Television Receiver—separator is fed from  $V_3$  anode; here the sync pulses are positive-going.

No R.F. portion of the set is described; this can be any of the types described elsewhere. The design given by W. T. Cocking in *Wireless World* of September 1947

can be used if its  $V_8$  is turned upside down (cathode to coil and anode to  $L_1$  and  $C_{17}$ ) so as to give the correct polarity signal which would then be taken from the junction of  $L_2$  and  $R_{18}$ ,  $V_8$  being omitted.

The power supply for the tube should be  $2\frac{1}{2}$ -3 kV negative. Note

that the 4-V, 1-A winding for the C.R. tube heater must be insulated to stand this voltage.

The 350-V supply (30 mA) can be the same supply as that used for the sound and vision receiver, and the 500-V line can be derived by adding on a 150-V supply to the top of the +350-V supply.

## News from the Clubs

**Baldock.**—Although formed only three months ago, the Baldock District Radio Club has a membership of over 40. Meetings are held on alternate Tuesdays at the Baldock New School; the next meeting is on June 29th. Sec.: N. F. Wiltshire, G3CEW, 13, The Tene, Baldock, Herts.

**Bexley.**—Future meetings of the North Kent Radio Society will be held on Mondays at 7.30 at Freemantle Hall, Old Bexley. The new secretary is J. L. Boves, G4MB, 20, Broomfield Road, Bexley Heath, Kent.

**Birmingham.**—The Midland Amateur Radio Society meets on the third Tuesday in each month at the Imperial Hotel, Temple Street, Birmingham, at 6.30. Sec.: W. J. Vincent, Junr., G4OI, 342, Warwick Road, Solihull, Birmingham, Warwick.

**Birmingham.**—The South Birmingham Group, R.S.G.B., which meets on the first and third Sundays in the month at 10.30 a.m. at Stirchley Institute, Stirchley, is organizing a weekly morse class. Particulars are available from the Area Representative, T. F. Higgins, G8JL, 391, Rednal Road, Northfield, Birmingham, 31, Warwick.

**Bradford.**—The Bradford Short-Wave Club has been disbanded. Former members are invited to join the existing Bradford Amateur Radio Society, which meets on Tuesdays at 7.30 at 66, Little Horton Lane, Bradford. Sec.: W. S. Sykes, G2DJS, 287, Poplar Grove, Great Horton, Bradford, Yorks.

**Bury.**—Meetings of the Bury and District Radio Society are held each Thursday, except the second Thursday in the month, at the club's headquarters, Spring Mills, Tottington, Nr. Bury, at 7.30. Monthly meetings of the R.S.G.B. are held on the second Thursday in the month at 7.30 at the Athenium, Bury. Sec.: R. H. McVey, 46, Holcombe Avenue, Elton, Bury, Lancs.

**Cannock.**—A course on fundamental radio is planned by the Cannock Chase Radio Society which meets at 7.30 on the second and fourth Tuesdays of each month at the Unicorn Inn, Church Street, Cannock. Sec.: D. M. Whitehouse, G2YV, 69, Church Street, Cannock, Staffs.

**Chatham.**—The Medway Amateur Receiving and Transmitting Society is planning to hold an exhibition in Chatham in November. Meetings are held on Mondays at 7.30 at the Co-operative Employers' Welfare Club, 207, Luton Road, Chatham. Sec.: S. A. C. Howell, G5FN, 39, Broadway, Gillingham, Kent.

**Cranwell.**—Associate membership of the R.A.F. Amateur Radio Society is limited to those who are, or have been, in the R.A.F. or the Dominion or Colonial Air Forces. Informal meetings of the Headquarters' Section are held on the second and fourth Tuesdays of each month at 6.0 at Cranwell. Sec.: N. Davis, No. 1, Radio School, R.A.F., Cranwell, Lincs.

**Kingston.**—Meetings of the Kingston and District Amateur Radio Society are held on alternate Thursdays at 7.30 at the Kingston Hotel. Next meeting July 1st. Sec.: A. W. Knight, G2LP, 132, Elgar Avenue, Surbiton, Surrey.

**Ramsgate.**—Membership of the Thanet Amateur Radio Society now totals 25 and includes nine licensed transmitters. Meetings are held on Wednesdays and Fridays at 7.30 at 11, School Lane, Ramsgate. Sec.: A. Jeffrey, Rutland House, Lloyd Road, Broadstairs, Kent.

**Southampton.**—A new club room has been opened by the Southampton Radio Club at 9, Bullar Road, Bitterne Park, Southampton, at which all meetings are now held. Meetings, which begin at 8 on Wednesdays, are preceded by half an hour's morse practice.

Sec.: J. A. Sillence, 80, The Drove, Cuxford, Southampton, Hants.

**South London.**—The former treasurer of the South London and District Radio Transmitters' Society, which was recently dissolved, asks us to record, for the benefit of former members, that the balance of the funds has been forwarded to the "Wireless for the Blind" Fund.

**Sunderland.**—In addition to the weekly meetings on Wednesdays the Sunderland Radio Society is arranging to start a series of lectures for beginners on Fridays. Meetings are held at 7.30 at Prospect House, Prospect Row, Sunderland. Sec.: R. A. Sharp, G2HMI, 137, Coronation Street, Sunderland, Durham.

## Standard Valve Data

This handbook gives the characteristics of standard valves from small triodes, for use in repeaters, to transmitting types. Mercury-vapour rectifiers and cathode-ray tubes are included, as well as a number of velocity-modulated tubes and X-ray tubes. Broadcast receiver-type valves are not included. It is obtainable from Standard Telephones and Cables, Ltd., Connaught House, Aldwych, London, W.C.2. Price 15s 6d (post free).



## Books Published for "Wireless World"

	Net Price	By post
<b>RADIO LABORATORY HANDBOOK.</b> Fourth Edition, by M. G. Scroggie, B.Sc., M.I.E.E. ... ..	12/6	12/11
<b>TELEVISION RECEIVER CONSTRUCTION.</b> A reprint of 10 articles from "Wireless World" ... ..	2/6	2/9
<b>FOUNDATIONS OF WIRELESS.</b> Fourth revised Edition, by M. G. Scroggie, B.Sc., M.I.E.E. ... ..	7/6	7/10
<b>WIRELESS DIRECTION FINDING.</b> By R. Keen, M.B.E., B.Eng. (Hons.), Fourth Edition, ... ..	45/-	45/9
<b>TELEVISION RECEIVING EQUIPMENT,</b> by W. T. Cocking, M.I.E.E., Second Edition ... ..	12/6	12/11
<b>WIRELESS SERVICING MANUAL,</b> by W. T. Cocking, M.I.E.E., Seventh Edition ... ..	10/6	10/10
<b>HANDBOOK OF TECHNICAL INSTRUCTION FOR WIRELESS TELEGRAPHISTS,</b> by H. M. Dowsett, M.I.E.E., F.Inst.P., and L. E. Q. Walker, A.R.C.S., Eighth Edition ... ..	30/-	30/8
<b>BASIC MATHEMATICS FOR RADIO STUDENTS,</b> by F. M. Colebrook, B.Sc., D.I.C., A.C.G.I. ... ..	10/6	10/10
<b>GUIDE TO BROADCASTING STATIONS,</b> Third Edition ... ..	1/-	1/1
<b>RADIO DATA CHARTS,</b> by R. T. Beatty, M.A., B.E., D.Sc., Fourth Edition—revised by J. McG.Sowerby, B.A., Grad.I.E.E. ... ..	7/6	7/11

Obtainable from all leading booksellers or from

ILIFFE & SONS LTD., Dorset House, Stamford Street, London, S.E.1.

# THE "BELLING-LEE" PAGE

Providing technical information, service and advice in relation to our products and the suppression of electrical interference

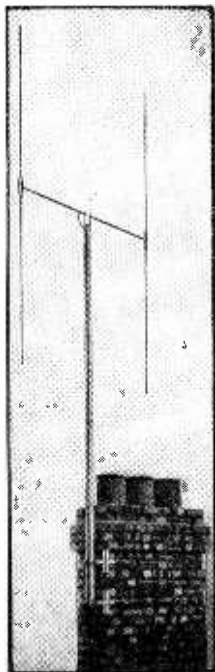

The illustration shows the "Belling-Lee" television aerial L502/L

## Birmingham Television

Orders are coming in for very large numbers of television aerials for use for the Midland television service. Everybody interested should bear in mind the fact that the reflector of a Belling-Lee television aerial can also be used as an anti-interference aerial\*1 to feed a normal broadcast receiver, so it is quite sound economics to install or to recommend the installation of such a system, even if the opening date has not been announced. Many wireless dealers served by Birmingham suppliers are in districts which obtain a reasonable picture from Alexandra Palace, and therefore it is very necessary to give the list number of the television aerial\*2 required—or at least to make it clear whether it is to receive the London or the Birmingham transmitter.

## Corroding of Aerials

From time to time we receive complaints that aerials show signs of rust. Many customers seem to expect them to last indefinitely without attention. We have often pointed out that iron lampposts and park railings receive their quota of

paint at very regular intervals. If it were not for continuous painting the Forth Bridge would have collapsed years ago. We give all steel aerials a protective coating before they leave the factory, but no finish will last for ever, and few for a year. We would like to make all our aerials from stainless steel, but many people would not pay the price. We are changing over to non-ferrous high tensile alloys whenever possible, but few have the strength of steel for a given section. We use these alloys in some types now. In their own interest users should have their aerial installation serviced once a year and dealers should recommend this course.

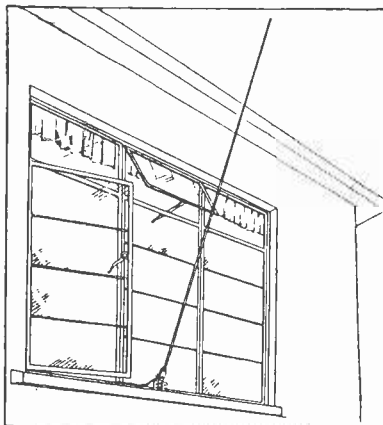

The illustration shows the "WINROD" aerial L581. Price 19/6. It is neat, inexpensive and easy to fix. An outdoor aerial of this type will always improve signal to noise ratio in relation to indoor types.

## No Purchase Tax on Aerials

It is an ill wind that blows nobody any good. Purchase tax is doing a great deal of harm to the radio industry. Meanwhile "Belling-Lee" cannot make aerials quick enough to meet the demand. The assumption is that rather than buy a new receiver people are treating their existing receiving to a decent aerial—and so obtaining better results than ever before. Even a "Winrod"\*4 (window mounting) aerial costing less than a pound will often give an improvement of 20 : 1 over the usual casual indoor aerial. Where situations and circumstances allow, a "Skyrod"\*5 with "Eliminoise" anti-interference transformers should be considered.

## Protection from Lightning

The thunder and lightning season is due; in fact we have already had a big storm. One customer rang up to tell us that his lightning arrester\*3 had "disappeared." His house fuses blew but his "Skyrod" and "Eliminoise" aerial were still working satisfactorily. "What should he do?" We explained that the lightning arrester had done its job, had undoubtedly saved the aerial, "Eliminoise" and receiver and should be replaced at once.

Every "Belling-Lee" aerial carries an insurance against lightning damage, which only becomes operative in the absence of any collateral cover. Normally, property is covered against this form of damage by a householder's comprehensive policy, as insurance companies do not regard the risk of an aerial as being worth an additional premium.

- ★ 1 U.K. Patent 520628.
- ★ 2 L502L Television aerial for London frequencies. L634 for Birmingham frequencies. Price £6 6s. each. Both types (as illustrated) include dipole, reflector and chimney lashings (less mast). Feeder is extra according to length and type required.
- ★ 3 Lightning arrester for anti-static aerials. L350. Price 9/6. Lightning arrester for balanced feeders. L376. Price 7/6.
- ★ 4 "WINROD" (Regd. trade mark). Window mounting aerial, each 19/6, sold in cartons containing 6 WINRODS.
- ★ 5 "SKYROD" (Regd. trade mark). 18 ft. five section vertical aerial for chimney mounting complete with "Eliminoise" anti-interference equipment. L638/K. £10

Kits with all straight sections and clamps for mast mounting will be known as L638/C collection only. L638/CK complete with "Eliminoise."

**BELLING & LEE LTD**  
CAMBRIDGE ARTERIAL ROAD, ENFIELD, MIDD'X

# LONDON CENTRAL RADIO STORES

Government Surplus—From Stock

## NEW MILNES H.T. UNITS (Everlasting)

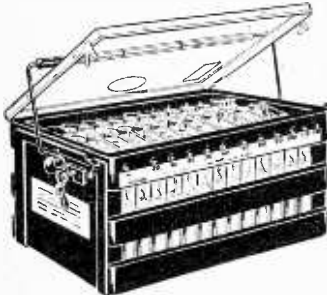

120 v. 60 mA. Will charge from 6 v. accumulator. For Calls only **67/6**

## A new purchase at reduced price 10-VALVE COMMUNICATION RECEIVER— Type R1155

These sets are as new. Need only a power pack for immediate use (see "W.W." July, 1946). Freq. range 7.5 mc/s to 75 kc/s in five wavebands. Complete with 10 valves, including magic eye. Enclosed in metal case. Every receiver is aerial tested. **10 Gns.**  
Set only

## THE FAMOUS EDDYSTONE 358 COMMUNICATIONS RECEIVER

Range 31 mc/s to 90 kc/s, 9 plug-in coils, 7 valves and rectifier, variable selectivity, B.F.O. stand-by switch, A.V.C. switch, bandspread dial, valve check meter. In heavy black crackle finished steel cabinet with chrome fittings. Complete with 200-250 v. A.C. Power Supply Unit. Carriage and packing 17/6 extra **£25**

**RADAR VIEWING UNITS.** Consisting of 6in. diameter Electrostatic C.R. tube, 7 valves, including four EF50, potentiometers, resistances and other associated components. In metal cabinet 18 x 8 x 7 1/2 in. Bargain price **£3.7.6**

## 3-VALVE R.F. AMPLIFIERS V.H.F. Type 25.

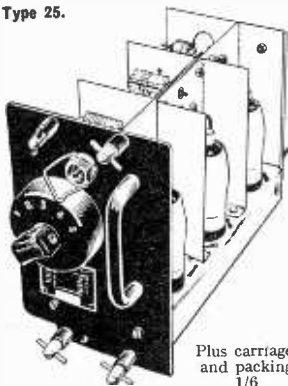

Plus carriage and packing 1/6

40/50 mc/s. Complete with valves. In metal case. Illustration shows unit with case removed. Brand new in carton **16/6**

Please Note.—We regret we cannot accept overseas orders, and we do not issue lists or catalogues.

## SLIDING RESISTANCES Suitable for Voltage Controls, Speed Regulators

**Type 867A.** 100 ohms on slider 3 amp. max. Tapped fixed 700, 800, 50, 50 ohms. **21/-** carr. paid.

**Type 868A.** 450 ohms on slider 2 amp. max. Tapped 200, 200, 200 ohms. **21/-** carr. paid.

**Type 866B.** 100 ohms on slider 5 amp. max. Fixed 200, 400, 50, 50 ohms. **21/-** carr. paid.

**VIBRATORS.** 2 v. input. Self-rectifying type. Output approx. 200 v. 600 mA. **7/6**

**EX-R.A.F. CINE CAMERA, Type G45B.** To take 16 mm. film. Fixed focus lens approx. 5 cm., f/3.5. In metal case. Dimensions 12 x 3 1/2 x 2 in. With 24 v. motor drive. **57/6**

## TELEPHONE LINE OR UNISELECTOR SWITCHES



BRAND NEW 3-BANK

26 constants. Have various applications, including automatic tuning, circuit selection, etc. Operates on 25-50 v. **45/-** Also a few secondhand 3-bank, **22/6**; 6-bank, **25/-**.

## FRACTIONAL H.P. A.C. MOTORS

Brush type, 220-250 v. 50 cycles, approx. 5,000 r.p.m. Overall diam. 10 x 4 in., 3/4 in. spindle extends 1 in. both ends. **25/-** Special reduction. Post 2/6 extra.

**PHOTO-ELECTRIC CELLS** Small infra-red image, glass converter tube. Type C.V. 143 50-100 v. Suitable for all purposes. Special price for 2 months only. **14/-** See April issue for illustration.

**2-VOLT POWER PACKS** complete with Vibrator Output approx. 200 v. 60 mA. Size 9 x 5 x 3 1/2 in. A first-class job, complete with accumulator in carrying case. **£3.7.6** Plus 5/- carr. and pkg.

**CHARGING BOARDS,** 24 v. 1,260 watts. **£4 19 6** Carr 12/6 extra. See April advt. for details.

DON'T TRY ANY TRICKS WITH A PUFF ADDER . . .

and if you don't believe us just ask any Indian fakir you see walking down the street and he'll tell you.

In a similar vein of thought don't try any tricks with Transformers under abnormal conditions, just make a firm resolve to think of the Parmeko Mercury series (hermetically sealed) when you desperately want -40c or +100c or when you're crazed for 50,000 ft. up or down to you know where.

Under such conditions just you try using Transformers which are not quite reliable and you'll start a chain reaction or get yourself puff addered - get what we mean?

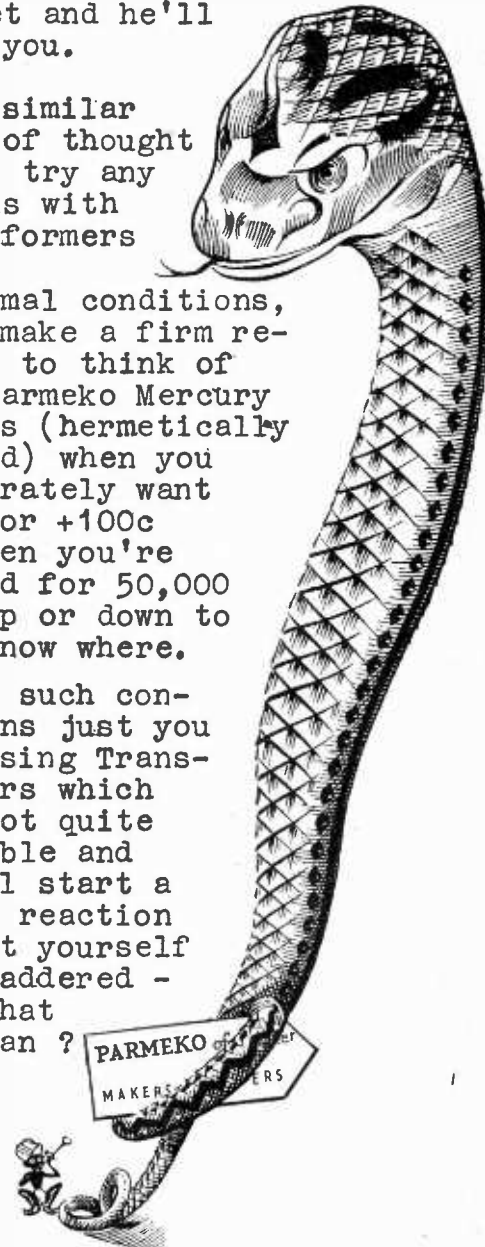

PARMEKO OF LEICESTER, Makers of Transformers for the Electronic, Signal, Luminous Tube, Oil Ignition Industries, etc.

**23, LISLE ST. (GERrard 2969) LONDON, W.C.2**  
Closed Thurs. 1 p.m. Open all day Sat. and weekdays 9 a.m.—6 p.m.



# Modulation, etc.

## A Theme and Seven Variations

By "CATHODE RAY"

THE pleasantest moments in putting together a jig-saw puzzle—or the alarm clock that one has rashly dissected—are when it suddenly becomes clear that the sub-assemblies which have been growing independently on different parts of the table fit one another along extensive frontiers to make an intelligible whole.

Modulation, Intermodulation, Harmonic Distortion, Heterodyning (or Beating), Frequency-changing, Detection, Rectification—these are subjects generally considered separately. I suppose all readers know something about all of them, but not everyone may be clear about the connections between them. The value of seeing the connections is that it generally sheds light on the individual subjects; just as the fragments of picture on the parts of the puzzle mean more when they are fitted together. What I am now setting out to do is to show that all the above subjects are just different aspects of one thing.

That one thing is what happens when A.C. meets non-linearity. "A.C." here stands for any alternating quantity of any frequency—"signals," oscillations, the output of the Electricity Board, sound waves, etc., etc. A non-linear thing, of course, is one whose graph<sup>1</sup> is not a straight line. To keep the discussion definite, let us agree to have in mind the input-voltage/output-current graph. Then the slope of the graph will represent resistance or conductance, according to whether the current scale is horizontal or vertical. Valves are all more or less non-linear, and so are iron-cored coils and some special types of resistors; but most resistors, capacitors and air-cored coils are linear.

The differences between the seven subjects listed above lie in the number and relative frequencies of the A.C. wave-trains,

and to some extent in the "shape" of the non-linearity. Instead of following custom by taking all these subjects separately, and then (perhaps) seeing what they have in common, let us consider the general subject of which they are parts—the A.C./non-linearity reaction, if you like—and point out what parts of it they are as we go along. The strictly logical method would be to do it all in one go, considering  $n$  frequencies in an entirely general non-linear circuit, because the simpler cases would all be included by it. But however logical it may be, it is very difficult for ordinary minds to work that way; which is why the highbrow books are so repellent. So we shall start with the simplest case we can think of.

The simplest A.C. waveform is undoubtedly the pure sine (or cos) wave. Reasons why have cropped up quite frequently in recent meditations, including the one on phase only last month. So, perhaps optimistically, I can take that as read.

But what is the simplest non-linearity? Presumably the sort that is easiest to handle mathematically.

At this stage it would be as well to consider the possible ways of expressing the raw material of our problem—the waveforms and non-linearities.

Any kind of either can be expressed as a graph. Graphs have the great advantage that they give the mind a picture. And it is not difficult—though it may be a bit tedious—to put the waveform graph and the non-linearity graph together and plot the result. Although this is very helpful and instructive, especially to the less brilliant and mathematically-minded, it is limited to the particular cases graphed, and a long time may be taken to reach general conclusions.

Any recurring waveform can also be expressed mathematically

as a sum of harmonically-related sine or cos waves (Fourier again). It may take a lot of different sized sinusoidal parts to make a synthetic copy of some waveforms found in nature; but quite simple combinations are enough for most of the interesting cases. Natural non-linearities can also be synthesized mathematically, but not always very well. A valve curve is easy enough to plot as a graph, but the best one can do mathematically is to try to fit it with one or more stock "functions."

Once reasonable approximations to the actual waveforms and non-linearity have been written down mathematically, it is perfectly straightforward (to the mathematician) to work out what must happen. The value of the method is that general principles can quickly be established.

The best way to understand a thing thoroughly is to look at it in as many different ways as possible.

The mathematical procedure is to write down the equations for the waveform and for the characteristic in question, and then substitute one in the other. Let us try it on a linear characteristic for the sake of example. Ohm's Law is a linear equation:

$$i = \frac{E}{R}$$

(This is not how it is usually written, but I have done it to separate the constant,  $\frac{E}{R}$ , the conductance, from the variable  $E$ . The small  $i$  and  $E$  are to show they are instantaneous values).

The alternating voltage might be, simply

$$E = E \sin \omega t$$

(where, as usual,  $E$  stands for the peak value and  $\omega$  for  $2\pi f$ ).

Putting them together

$$i = \frac{E}{R} \sin \omega t$$

Which means, of course, that the output current is exclusively at the same frequency as the input, and therefore has the same wave-

<sup>1</sup> To silence the purists, more specifically "graph with linear Cartesian co-ordinates."



**Modulation, etc.—**

form, and its peak value is  $\frac{E}{R}$ .

The graphical procedure is to draw the graph of the charac-

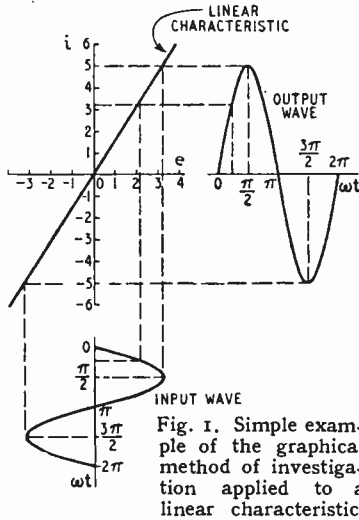

Fig. 1. Simple example of the graphical method of investigation applied to a linear characteristic.

teristic as in Fig. 1, where 0 is the working point ( $e = 0, i = 0$ ). The input waveform is stood on its end, usually underneath, so that the same voltage scale applies to both. The other scale for the input waveform is time or angle (see "Phase" in the May issue), and this is duplicated horizontally at one side for the output waveform, which is traced out from the input via the "curve." The route is: any point on input time scale, along to input wave, up to characteristic, along to intersect upright from corresponding point on output time scale, giving point on output wave. It is hardly necessary to say that the result, when the points are joined up to give the output wave, agrees with the mathematical one.

**Quadratic Curvature**

Going back to the question of the simplest sort of non-linearity; when we were at school the next step after simple (or linear) equations was the quadratic (or square-law or second-power) variety. This introduces an  $e^2$  term, which is generally in addition to an  $e$  term and probably a constant term. A square-law equation can be tailored to fit almost any valve's "bottom bend" fairly neatly, but it soon grows out of it at each

end. So one has to be careful not to stretch it too far.

Keeping again to the barest simplicity we could say,

$$i = ae^2$$

in which  $a$  is a general constant.

Putting in the same waveform as before:

$$i = a (E \sin \omega t)^2 = aE^2 \sin^2 \omega t$$

Using one of the mathematicians' stock results turns this into,

$$i = \frac{aE^2}{2} (1 - \cos 2\omega t).$$

Which means that the output consists of two parts, one at zero frequency, equal to  $\frac{aE^2}{2}$ , and the other at twice the original frequency—a second harmonic.

Incidentally, the harmonic, being a cos, is  $90^\circ$  out of phase with the input. There is nothing at all at the input frequency; so an amplifier conforming to the above law would hardly be deemed a triumph of high fidelity. Two phenomena have been illustrated, however—rectification and harmonic distortion. They are due entirely to the non-linearity.

Looking at the same thing graphically, Fig. 2 shows the graph of  $i = ae^2$ , with 0 as the working point. It is not at all typical of actual circuits, because the current is equally positive whether the voltage is positive or negative; but it will do as a comparison.

The result shows all the features indicated by the previous method—total rectification, D.C. component equal to half the peak value, second harmonic with same

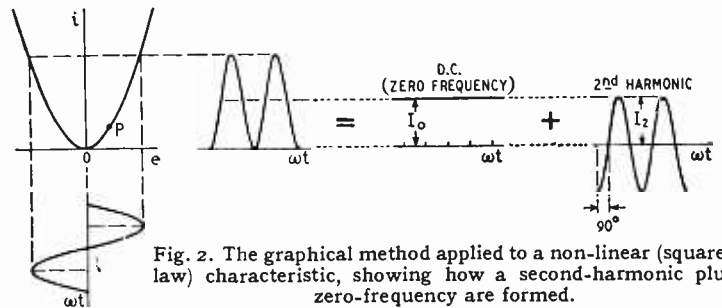

Fig. 2. The graphical method applied to a non-linear (square-law) characteristic, showing how a second-harmonic plus zero-frequency are formed.

peak value as the D.C., and the  $90^\circ$  phase shift.

In real circuits the left-hand upward part of the curve is generally non-existent, and P is a more typical working point.

And there is likely to be a linear term to straighten the curve a bit. So it is quite abnormal for the original frequency to be entirely missing from the output. The general result of applying a single-frequency  $f$  to a second-power (square-law) characteristic is an output at frequencies, 0,  $f$  and  $2f$ . A triode amplifier characteristic approximates closely to a quadratic equation in which the  $e^2$  term is relatively small so most of the output is in the  $f$  term. An anode-bend detector is another example, in which the  $e^2$  term is made as large as possible, to make the D.C. output large.

With diode detection or rectification, if the input is, say, 25 volts or more, the bend looks comparatively small and the

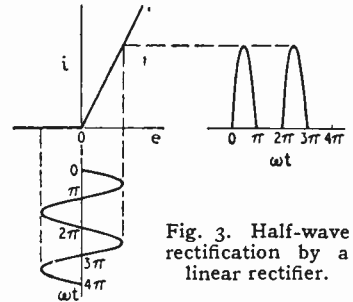

Fig. 3. Half-wave rectification by a linear rectifier.

characteristic approximates more closely to Fig. 3. This as a whole is not expressible as a simple mathematical function, but it is easy to see that the output consists of half-cycles, and that the analysis of them would again show a substantial proportion of D.C. That, of course, is generally the

only part that a rectifier is intended to provide. The other frequencies, collectively termed "ripple," are nuisances which necessitate a smoothing filter for their removal. The fundamental

is fairly clearly present ; and there is not only just the one even harmonic, but an infinite series of them rapidly diminishing in size with rising frequency ; for practical purposes all except the first few can usually be neglected. There are no odd harmonics.

When the output of another

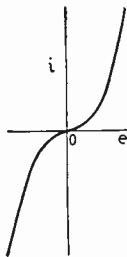

Fig. 4. A pure cube-law characteristic.

half-wave rectifier is added to give full-wave rectification, the D.C. component is doubled and the fundamental goes out, leaving mainly second-harmonic ripple.

To avoid jumping to a wrong conclusion that all non-linear characteristics rectify, perhaps we had better go another step up and consider the cubic or third-power characteristic, which is distinguished by an  $e^3$  term.

Taking a neat dose of this, in the form

$$i = be^3$$

and plotting it, we get Fig. 4. A feature of this, if one works from the point  $o$ , is that positive and negative output half-cycles are equal, so there is no D.C. If worked at some other point by applying a bias, say  $v$ , then multiplying out  $(v + e)^3$  gives terms in  $e^2$ ; so a cubic law can rectify. Fig. 4 doesn't resemble any likely valve characteristic as it stands (though it is something like certain special voltage-limiting resistors); but if turned on its side it shows the peak-flattening at both ends which is characteristic of a pentode when the load resistance is not small. At low loads the pentode gives bottom-bend or second-harmonic distortion; but as it is increased the top end is flattened too and it is possible for the two to balance so that rectification and second harmonic disappear. But there is usually a mixture of both.

A general rule is that an  $n$ -power characteristic yields  $n$ th harmonic; but the most practically important are square-law, yielding second harmonic and D.C.; and cube law, with third harmonic and no D.C. (unless three is a square term too).

Another important law is the exponential, because it fits so many valve and rectifier curves tolerably well, and is mathematically manageable in spite of consisting of an infinite series of power terms.

In this "Stump the (Technical) Author" game I have now brought in three of the seven given objects (or rather subjects)—Harmonic Distortion, Rectification, and Distortion—but admittedly detection has only a limited interest when confined to an unmodulated carrier wave. Modulation immediately introduces more than one frequency; so let us face it.

A constant source of wonder to the non-technical is how dozens of musical instruments can be recorded simultaneously in one groove without getting "mixed

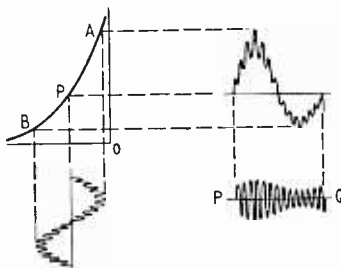

Fig. 5. One of the simplest cases of intermodulation, in which the graphical method shows the main results.

up." In principle it is no more nor less wonderful than being able to hear them direct through one medium—air, though that seldom evokes comment. So long as everything on route is linear, the original frequencies cannot modify one another, or produce any extraneous frequencies.

That can be shown very easily indeed by the algebraical method; but the graphical method is most laborious, because of having to add together the plots for the two or more input waves and then to analyse the output to find what frequencies it contains. With non-linear characteristics it is worse still, of course; and one is practically forced to use the sin-and-cos method. But since I feel it is almost cheating, not to offer at least the alternative of a diagram, let us take a case that is easy to follow, in which one signal is much stronger and

lower than the other. It might be an organ pedal note ( $f_1$ ) and a high note ( $f_2$ ) being amplified together, say by a triode. Fig. 5 shows a dynamic characteristic curve, working point P. The two signal frequencies in this example are easily distinguishable even when added together.

When the output waveform has been derived—a tedious job this time—it is obvious that the output includes both the original frequencies, and that the low tone shows typical second-harmonic distortion—one peak sharpened and the other flattened. The high tone is continually being carried by the low tone from one part of the curve to another, but wherever it is there is some square-law curvature, so it too is subject to slight second-harmonic distortion. All this is as before. The new feature is that when the high note is near A it is amplified more than when it is near B. This is shown more clearly by separating it from the low tone as at PQ. The low tone has left its mark on the high tone even after it has been removed. In other words, the low tone has modulated the high note.

This is where it becomes difficult to identify the frequencies concerned. But as we went through it all in "Sidebands Again,"<sup>2</sup> I will just remind you that what is happening is that the  $f_2$  vector is being alternately lengthened and shortened at frequency  $f_1$ , and that the way to make a vector behave thus is to add two other smaller vectors rotating in opposite directions at frequency  $f_1$  relative to  $f_2$ . (Fig. 6.) There

Fig. 6. Vectorial "working model" of modulation. The whole thing is rotating anti-clockwise, but the  $f_2$  rotation has been "frozen" to show the relative rotation of the  $f_2 + f_1$  and  $f_2 - f_1$  side frequencies.

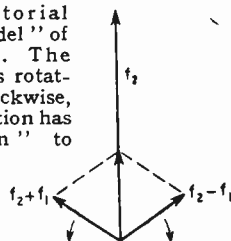

being two sideband vectors makes sure that the combination of the two is always in line with the  $f_2$  vector, so can be added or subtracted without shifting its phase.

<sup>2</sup> December, 1947 issue.

**Modulation, etc.—**

That is pure amplitude modulation. And it is easy to see that the maximum amplitude of each side frequency for 100% modulation is half that of the carrier wave.

Here we are talking in terms of modulation, as in radio transmitters, when our example was supposed to be distortion in an A.F. amplifier. It just shows they are fundamentally the same. There is one difference, which is not very prominent in our example because for simplicity I chose a relatively weak  $f_2$ . But however weak, it does shift  $f_1$  some way up and down the characteristic, thereby modulating it a little. If the two signals were equally strong they would modulate one another equally. The modulation of signals by one another is what is called Inter-modulation. It is the form of distortion due to non-linearity (additional to harmonic distortion) represented by combination frequencies. Supposing our characteristic to have first and second powers (linear plus square-law),  $f_1$  and  $f_2$  separately would give frequencies 0,  $f_1$ ,  $f_2$ ,  $2f_1$ , and  $2f_2$  in the output. Together intermodulation adds  $f_1 + f_2$ ,  $f_1 - f_2$ ,  $f_2 + f_1$ ,  $f_2 - f_1$ .

$f_1 + f_2$  is obviously the same as  $f_2 + f_1$ , so as regards frequency at least they are indistinguishably lumped together. And  $f_1 - f_2$  and  $f_2 - f_1$  are the same, except that one is positive and the other negative. But what, if anything, does a negative frequency mean?

That is an intriguing question which must be left until another time. In the meanwhile let us do what most of even the best textbooks do, and quietly forget the negative sign, regarding  $f_1 - f_2$  and  $f_2 - f_1$  as the same thing.

Tackling intermodulation mathematically, you write down the equation representing the signal, which this time must include at least two frequencies, say

$$e = E_1 \sin \omega_1 t + E_2 \sin \omega_2 t.$$

Using the very simple non-linearity again,

Squaring  $e$  in its detailed form above gives multiplication terms, such as  $E_1 E_2 \sin \omega_1 t \sin \omega_2 t$ . Since any non-linear equation has power higher than 1, they are inevitable. Using stock transformations to

reduce them to their component single frequencies yields the familiar sum and difference side-band terms (hereinafter called  $\pm$  frequencies).

These  $\pm$  frequencies are generally more or less discordant relative to the original ones, which is why non-linearity distortion sounds so bad. The accompanying harmonics, being harmonious (if they are low-order), are comparatively harmless. They are merely easily-measurable symptoms of the main trouble.

I have no space to go through the same story for cubic or higher order non-linearity, but the trig.

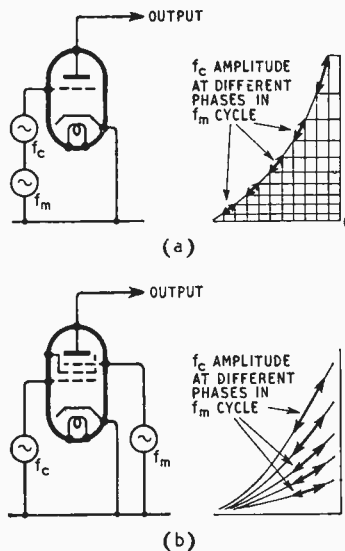

Fig. 7. The two varieties of modulator. In both, the modulating signal controls the amplitude of the signal to be modulated; but in the "additive" type (a), which corresponds to Fig. 6, it works in the same circuit, whereas in the "multiplicative" type (b) it works independently.

experts can easily show, and the vector fans fairly easily satisfy themselves, that a cubic term in the characteristic generates an extra lot of side frequencies, specified by terms such as  $f_2 + 2f_1$  and  $f_2 - 2f_1$ . These generally sound even more unpleasant than the first-order differences.

What is an undesirable distortion when amplifying audio frequencies is fundamentally the same process as that by which those audio frequencies can be raised to a radiatable frequency for broadcasting. Suppose  $f_m$  is

any A.F. and  $f_c$  is an R.F. oscillation; then adding them together and passing them through a non-linear device yields  $f_c$ ,  $f_c + f_m$  and  $f_c - f_m$ —all radio frequencies—which can be broadcast to innumerable receivers, where the  $f_m$ , or any number of audio  $f$ 's, can be extracted for the edification of the public.

If the modulator characteristic were to have higher powers than 2, frequencies would be generated which the receivers would turn into A.F. harmonics, and rude letters would be written to the B.B.C. about it. As a matter of fact this "additive" modulator at best is not a very efficient one. In practice there is a choice of alternative methods, fully described in the books, I will only draw attention to an important—though not really fundamental—difference between these and the additive method.

When the two (or more) signals are added, they modulate one another, or intermodulate, in the non-linear device. It is true that if one is much stronger than the other the contest is rather one-sided; the modulation of the strong by the weak may be negligible. But if the modulating signal is applied in some way in which it can control the amplitude of the signal to be modulated, without the latter being able to "hit back," there is modulation without intermodulation. One way is to apply the modulating signal to the anode of a valve which is amplifying as linearly as possible; another is to apply it to the suppressor grid. The relevant characteristic of the valve is then a 3-dimensional affair, which cannot be shown adequately on a piece of paper, and only enthusiasts carve the necessary models. But it is not difficult to see that if varying the voltage of the anode (or suppressor grid) varies the amplitude of the R.F. signal then being amplified or generated linearly via the control grid (Fig. 7b), the general effect on the R.F. is much the same as if it acted via the control grid on a non-linear part of its characteristic (Fig. 7a), so that  $\pm$  frequencies will be formed. Supposing the amplification is directly proportional to the voltage of the modulating electrode, which is being varied sinusoidally, then



the output must be expressed mathematically as the sin (or cos) of the R.F. multiplied by the sin (or cos) of the modulating frequency; so one arrives at the  $\pm$  frequencies again from a slightly different starting point.

At the receiving end there must be arrangements for accepting the whole bunch of radio frequencies— $f_c$ ,  $f_c + f_m$  and  $f_c - f_m$ . In effect even if not in name, it ought to be a band-pass receiver. After any necessary amplification the bunch is passed together into a non-linear device—the detector. From our previous consideration we know that even if the detector characteristic is no higher than square-law the resulting frequencies are liable to include the input ones, plus R.F. harmonics, plus zero frequency, plus  $f_c + (f_c + f_m)$ ,  $f_c - (f_c + f_m)$ ,  $f_c + (f_c - f_m)$ ,  $f_c - (f_c - f_m)$ ,  $(f_c + f_m) + (f_c - f_m)$ , and  $(f_c + f_m) - (f_c - f_m)$ . All except four of this alarming array are found on examination to be radio frequencies, which can be filtered out. Of the four, one is Z.F., which can be ignored or used for A.G.C.; two are  $+f_m$  and  $-f_m$ , which we have agreed to call just  $f_m$ ; and the other is  $2f_m$ . With a "linear" detector (strictly a contradiction in terms, but it means one like Fig. 3) there is theoretically an infinite number of output frequencies; but, as the graphical method shows much more simply, if less vigorously, all the A.F. ones cancel out except  $f_m$ .

Detection, then, is just another case of intermodulation.

If the carrier wave is unmodulated, the only possible frequencies are 0,  $f_c$ , and harmonics of  $f_c$ , none of which is audible. But if the receiver has a local beat oscillator capable of generating a frequency differing from  $f_c$  by an audible frequency (say  $f_c - f_m$ ), and feeding it to the detector along with  $f_c$ , the input frequencies are the same as if the carrier wave were modulated, except that there is only one side frequency. So long as the detector has a square term in its characteristic, as it must to be a detector, the audible difference frequency  $f_c - (f_c - f_m) = f_m$  appears again. One might ask, then, why have two sidebands?

The answer (after a brief pause to register the fact that heterodyning—or beating—can now be ticked off the list) is that if one

sideband is omitted, or lost in an overselective tuner, there is distortion, especially with deep modulation. Compare the result of working Fig. 6 (having made each sideband vector half as long as the carrier vector) for one cycle, with an arrangement in which one side vector is abolished and the other is of the same length as the carrier. The first combination adds up to a resultant vector that varies its length sinusoidally, and if it were rotating at high speed ( $f_c$ ) its waveform diagram would look like Fig. 8a. The other gives an obviously distorted modulation "envelope"—Fig. 8b.

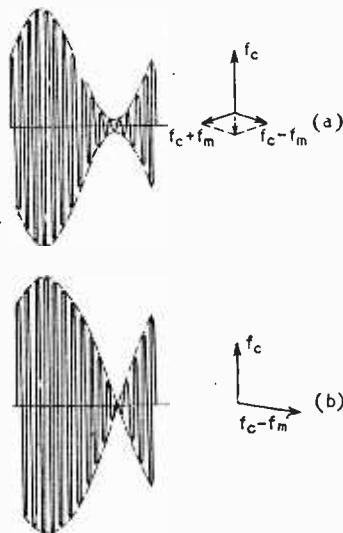

Fig. 8. (a) is the waveform of true 100% modulation, with a carrier wave and two half-size side waves. (b) is heterodyning—distorted 100% modulation—with a carrier and one equal-size beating wave.

The distinction between the two becomes less if the depth of modulation is reduced; and it is also rather interesting that a square-law detector, which would distort  $f_m$  in Fig. 8a, would neutralize the distortion in Fig. 8b.

In a superhet receiver there is an example of frequency-changing. I must have said enough for this to be easily recognizable as another case of modulation. The only difference is that the modulating frequency, instead of being audible, is generally even higher than  $f_c$ ; and instead of selecting the original carrier (with its original sidebands) and the new  $\pm$  frequencies (which will also

have the same sidebands), the I.F. amplifier is tuned to only one of the three bunches—either the + or the —.

The early superhets used frequency-changers of the additive type. In case that sounds too historical it can be noted that so does the most modern radar. Of course merely adding together the incoming signal and the locally-generated oscillation does not produce any new frequencies. That is why I dislike the term "mixer." Mixing oxygen and hydrogen yields—oxygen and hydrogen. A better word for the non-linear device would be "combiner," because it yields the  $\pm$  frequencies, which are often called combination tones. The American "converter" is not so good, because "convert" just means to turn round. The slow "beats" produced when two nearly equal audible frequencies are sounded together are not themselves sounds—the frequency would be below audibility even if they were. They have a waveform like Fig. 8b, in which the "high frequency" is itself audible, as are also its variations in loudness.

Modern domestic superhets have "multiplicative" frequency changers. Both types are really multiplicative in principle, as we have seen; the term "additive" just means that the inputs are added and subjected together to the non-linearity, whereas in the so-called multiplicative type the modulated frequency never "sees" the modulating frequency, which influences it by means of some other characteristic of the modulator, such as that of grid No. 3 in a hexode.

Most receivers also have a power rectifier. We considered this quite near the start; but it is interesting to look at it, too, as a modulator. The 50-c/s input carries the rectifier up and down and around its very non-linear characteristic, modulating itself. The first-order  $\pm$  frequencies are 0 and 100 c/s, the former is what one wants, and the latter gives the smoothing circuit a job.

So once we have learnt a technique for working out what happens when two frequencies are passed simultaneously through a non-linear device (and, alternatively, when one of them exerts the same sort of influence from a

**Modulation, etc.—**

privileged position) we can treat all the seven subjects as minor variations. Apart from technical details, the main differences are the frequencies one wants from the output. With harmonic and intermodulation distortion it is the original frequencies; all the new ones are pests. With a rectifier it

is the zero frequency. With detection and heterodyning it is the minus frequency. With frequency changing it is either plus or minus frequency, according to circumstances. With normal amplitude modulation it is both, and the carrier between; but in special cases the carrier and/or one sideband can be left out.

I have gone into this rather lengthily because a good foundation will help when tackling some future topics, including negative frequency and frequency modulation. There is also what might be regarded as an eighth variation on the theme—the Synchrodyne, which, being comparatively new, deserves a chapter to itself.

## Millimetre Wavelengths

### 8-9mm Velocity-modulation Valve

**A** NEW velocity-modulation valve, tunable over the range 8-9 mm, was shown recently at the Telecommunications Research Establishment. It has a continuous-wave power output of some 10-20 mW and operates with 2.4 kV between cathode and resonator and with the reflector at 200 V negative to the cathode. The current in the gap is about 7 mA.

Designed by the Clarendon Laboratory, the valve involves a number of metal-glass seals. As shown in the sketch the electron gun is contained in a glass tube which is sealed to a copper disc of corrugated form, and having a central hole, or gap, for the passage of the electron beam. This copper plate forms one wall of the resonator and a somewhat similar plate, which forms the other wall, is spaced from it by a glass ring. Beyond this a copper

thimble is soldered to the plate. This is of smaller diameter than the glass tube surrounding the

resonator as a whole is in two parts, one outside and one inside the evacuated body of the valve.

This metal ring is pierced by a rectangular hole which forms the initial part of the waveguide through which the output is taken.

Tuning is accomplished by moving the two ends of the valve relative to each other. The gun end is clamped firmly in a rigid support. The reflector end is clamped in a holder which can be moved longitudinally by a cam mechanism.

In covering the band 8-9 mm, a movement of only  $\pm 0.005$  in is needed and the

corrugated side members of the resonators can spring this much. It is, of course, only the volume of the inner part of the cavity which changes.

So far, the valves are hand-made, but accurate jigs are needed, especially for obtaining the resonator spacing. The glass tube has internal flanges for centring the gun and the resonator spacing is obtained by means of accurate steel pins which are withdrawn when the glass spacer has been brought to the right size and the sealing accomplished.

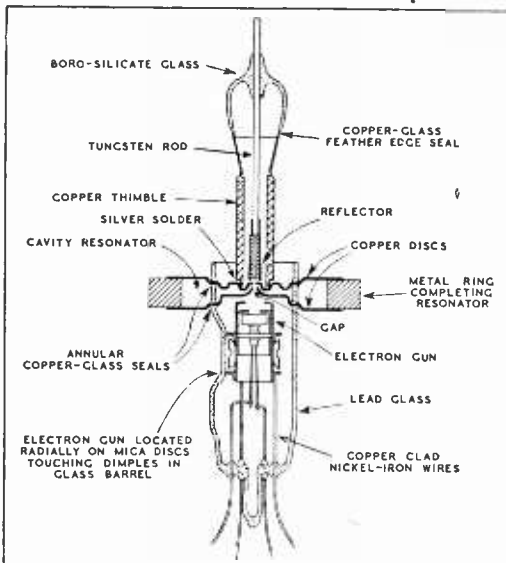
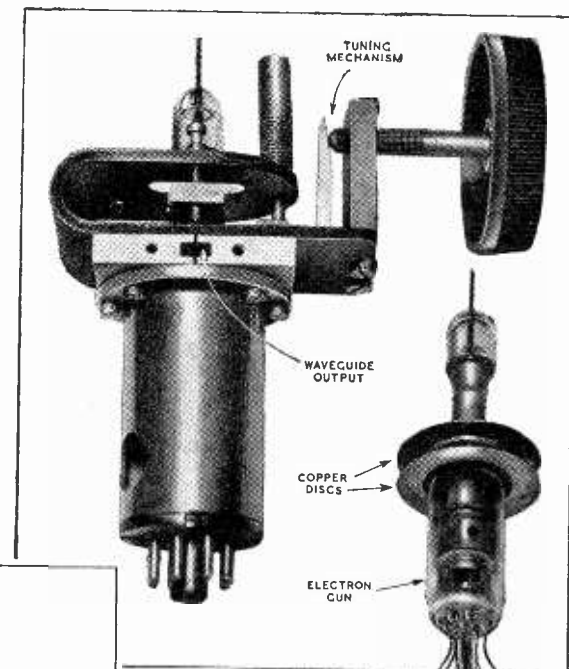

The sketch on the left shows the construction of the valve, and the photograph above illustrates both the valve itself and the tuning mechanism.

gun, and contains the reflector. The resonator is completed by an external metal ring joining the two copper plates, so that the



# PHILIPS

## SOUND AMPLIFYING EQUIPMENT

### THE "VOXMOBILE" AMPLIFIER

Type 2856R

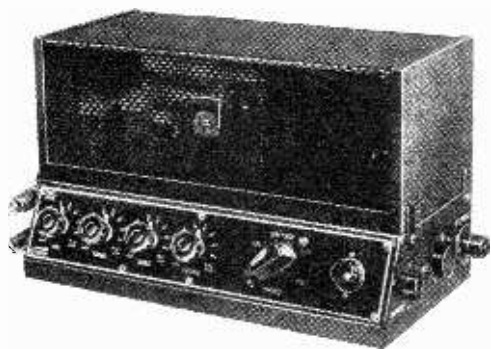

**Mobile — Indoor — Outdoor**  
**Operates from A.C. Mains**  
**or 12-volt Battery**  
**Output:—12 watts. Self-contained**

The Voxmobile is a really versatile amplifier. While it produces excellent quality, it is light, quickly connected, and operated equally as well either from A.C. mains 250 volts or a 12-volt car battery.

One of the outstanding features of this amplifier is the high sensitivity; only 3.5 mv being required into 1 megohm to produce the full output, thus allowing wide pick-up and the use of high quality microphones.

**List Price : £38 . 0 . 0**

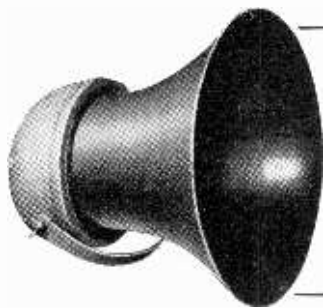

### Loudspeaker Type 9816T

Excellent reproduction and wide angle distribution.  
Weatherproof — light — robust.  
For use Outdoors, Indoors, or on a Vehicle.  
No back radiation and therefore minimum feed-back.  
The ideal " general-purpose " quality P.A. Speaker. Complete with line transformer tapped at either 1, 3 or 6 watts.

**List Price : £8 . 0 . 0**

### Complete Voxmobile "All-Purpose" Equipment

The ideal general-purpose equipment for Dealers and for Religious, Political, Social and Sporting Organisations.

Comprises :— Amplifier, high fidelity microphone on floor stand, with 15-ft. special microphone cable, and two type 9816T speakers.

**List Price : £66 . 15 . 0 Available to all bona fide Traders**



# IT WAS ALWAYS A "SOUND" IDEA TO SAVE TIME.

Announcing the Auto-Call System which enables you to communicate with anyone in any part of the factory without the help of your switchboard and without complicating your existing interphone system.

DESIGNED FOR USE IN OUR OWN FACTORY, TEN YEARS AGO, AND NOW REGARDED AS INDISPENSABLE.

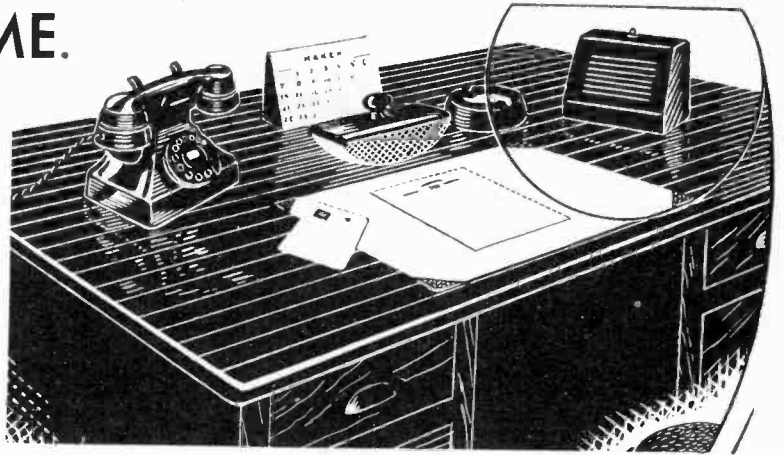

## SOUND SALES LTD WEST STREET, FARNHAM, SURREY.

Telephone: FARNHAM 6461-3. Telegrams: "SOUNSENSE."

LONDON OFFICE: 57, St. Martin's Lane, London, W.C.2. Telephone: TEMPLE BAR 4284. Telegrams: "SOUNSENSE, LONDON."

AGENTS: Barnes & Avis, Reading; Bowers & Wilkins, Worthing; Binns Ltd., Newcastle; Dalton & Sons Ltd., Derby; Clark & Sons, Isle of Wight; Hickie & Hickie Ltd., Reading (and branches); Holley's Radio Stores, London, S.E.5.; Jewkes & Co., Birmingham; Thomas Lynn & Sons, Andover; Merriotts Ltd., Bristol; Needham Engineering Ltd., Sheffield; Pank's Radio, Norwich; Sound Ltd., Cardiff; Bernhard Smith, Barnstaple; Sound Services, Jersey, C.I.; Precision Services, Edinburgh; Seals Ltd., Southsea; G. E. Samways, Hazel Grove; Weybridge Radio Electric, Weybridge; West End Radio, Farnham; Vallance & Davison Ltd, Leeds (and branches).

Overseas Stockists in Canada, South Africa, Channel Islands, etc.

*The* **LOWEST EVER**  
*attenuation & capacitance*

**CO-AX**  
*air insulated, articulated*  
**CABLES for R.F.**

TRANSRADIO LTD · 138A CROMWELL ROAD · LONDON, S.W.7

**CO-AX**

LOW ATTEM. TYPES	IMPEDANCE OHMS	ATTEN. db/100ft. at 100 Mc/s	LOADING kW	O.D.
A 1	74	1.7	0.11	
† A34	73	0.6	1.5	0.36" 0.85"

LOW CAPAC. TYPES	IMPEDANCE OHMS	CAPAC. mm/ft.	BREAKDOWN Volt	O.D.
C 1	150	7.3	1100	
XPC1	132	10.2	950	0.36*
C 11	173	6.3	800	0.36*
C 22	184	5.5	900	0.36*
C 33	220	4.8	1000	0.44*
C 44	252	4.1	1150	0.64*

† Bending radius 5"  
★ Photocell cable.

Write for Characteristics of further types.

## WORLD OF WIRELESS

# T.R.E.'s New Task ♦ P.T. on Radio ♦ Europe's Wavelengths ♦ Television Servicing Exam.

### POST-WAR T.R.E.

THE Telecommunications Research Establishment, whose wartime achievements in developing radar have been acclaimed as one of the most notable examples of successful scientific team work, has now settled down to its peacetime routine. T.R.E. is now divided into three main technical branches—radar, physics and engineering—and, in addition to its function of developing radio equipment for the R.A.F. and Naval Air Arm, also produces radio aids for civil aviation. A programme of basic research in radio and electronics, partly sponsored by the Department of Scientific and Industrial Research, is under way.

An "open days" exhibition recently held at T.R.E. headquarters, Great Malvern, allowed many visitors from the Universities, Government establishments, the Services and industry to see the work in progress. *Wireless World* was especially interested in the centimetric radio sonde equipment, the "suppressed" or built-in aerials to reduce aircraft drag, the ultrasonics section, a new airborne cloud and collision warning equipment, and in an exhibit showing the influence of wavelength on receiver design. T.R.E. does not neglect the practical side, and some radically new constructional techniques were seen. Millimetre-wave work is being conducted; a special valve for the 8-9 mm band is described on p. 258.

Thanks to the excellent organization of the "open days" by G. W. A. Dummer, it was possible to obtain a clear picture of the peacetime activities of T.R.E.; we hope shortly to publish articles on some of the Establishment's activities.

### B.B.C. RESEARCH

THE appointment of a Scientific Advisory Committee "To advise on the B.B.C.'s scientific research and its correlation with external activities in the same field" is announced by the Corporation.

Sir Edward Appleton, Secretary, D.S.I.R., has accepted the invitation to be chairman of the Committee. The vice-chairman is Sir John Cockcroft, director, Atomic

F. STONER, United Nation's Chief Engineer of Communications, at the Console of the new U.N. radio station K2UN.



Energy Research Establishment. The invitation to serve on the committee has also been accepted by Dr. H. G. Booker, Christ's College, Cambridge; Professor Willis Jackson, Imperial College of Science and Technology; Dr. R. L. Smith-Rose, Director of Radio, D.S.I.R.; and Professor F. C. Williams, Manchester University.

### PURCHASE TAX DOWN

THE radio industry has made an excellent case for the reduction of the Purchase Tax on receivers from 66 $\frac{2}{3}$  per cent to 33 $\frac{1}{3}$  per cent. A few days before the opening of the Budget debate in the House of Commons a deputation from the Radio Industry Council, led by J. W. Ridgeway, met the Economic Secretary to the Treasury and stated the industry's case. Tax is reduced to 33 $\frac{1}{3}$  per cent on all domestic and car receivers, kits of parts, television sets, valves and cathode-ray tubes. The reduction does not apply to radio-gramophones, which remain chargeable at 66 $\frac{2}{3}$  per cent.

Convincing arguments against the increase of tax were adduced not only by the organized industry but by individual firms. The following extract is from a letter written to local M.P.s by the workers in Wright and Weaire's factory in South Shields: "In the radio industry we have the direct antithesis of inflation. Here, instead of too much money chasing too few goods we have too many goods and a falsely restricted demand. Is therefore the industry to be penalized for its resource in overcoming the material supply positions of the day and making available the greater quantity of goods which we understood was the answer to our inflationary problems?"

The recent ruling (see last issue) regarding P.T. on public address equipment has been criticized by the Elec-

tronic Manufacturers' Association which states that it is at variance with the previous agreement to regard tax as payable only on the wireless or gramophone units when fitted into a rack assembly. It is pointed out that a literal reading of the new ruling would raise the tax on some P.A. gear from £15 to £200!

### INTERNATIONAL CONFERENCES

DURING the next few weeks a number of important international conferences will be held. The most important is the European Regional Broadcasting Conference which opens in Copenhagen in July. This will be attended by representatives from all the countries in the European Area (see map on p. 149, April issue) which were signatories of the Atlantic City Convention. This conference will draw up a new regional agreement for European broadcasting and a frequency allocation plan.

The preparatory work for the latter has been undertaken by an eight-country committee which has submitted alternative plans to the interested countries. The plan covers the allocation to broadcasting stations of frequencies below 1,605 kc/s. The medium-wave band will extend from 525 to 1,605 kc/s instead of from 550 to 1,560 kc/s.

The Union Radio Scientifique Internationale, of which Sir Edward Appleton is the president, will meet in Stockholm from July 12th-22nd. The work of the U.R.S.I. is undertaken by four commissions, dealing with (a) standards and measurements (b) propagation; (c) radio noise and (d) radio physics. It will be recalled that a convention was held at the I.E.E. in April to facilitate the correlation of this country's contribution to the meeting.

The Comité Consultatif International des Radiocommunications



### World of Wireless—

(C.C.I.R.) also meets in Stockholm in July. This advisory committee of the International Telecommunication Union deals with technical radio problems.



PLAQUE of the memorial recently dedicated at Lavernock to commemorate the first radio message transmitted across water—between Lavernock and Flat Holm on May 11th, 1897.

### R.T.E.B. TELEVISION EXAM

A SYLLABUS has been issued by the Radio Trades Examination Board as a preliminary toward holding a television servicing examination. The proposed date of the first examination is May, 1950, and details of the written paper and the practical tests will be issued later.

The syllabus, which is obtainable from the R.T.E.B., 9, Bedford Square, London, W.C.1., has been issued as a guide to students and teachers of the requirements of both the written and practical tests. Candidates must be holders of the Board's certificate in radio servicing, the next exam for which will be held in May, 1949.

A booklet will be issued by the Board in September giving details of both examinations, and a list of schools and colleges offering coaching.

### P.O. AND WIRED WIRELESS

IT is apparent from the announcement in *The Post Office Electrical Engineers' Journal* (April, 1948) of the formation of a Local Lines and Wire Broadcasting Branch of the G.P.O. Engineering Department, that the idea of transmitting radio programmes by means of Post Office telephone lines has not been shelved. It will be recalled that the Post Office project for wired broadcasting in Southampton was still-born in 1939 owing to the protests lodged by the industry and the Borough Council.

One section of the new Branch is

concerned solely with development work on wire broadcasting.

### APPLIQUÉ RADIO

WE have on various occasions lamented the inability of the radio fraternity to coin the apt name for the new thing. A case in point is the new method of receiver construction by "printing" or "spraying" the wiring and some of the components on to an insulating base. So far there is no all-embracing term for these various methods of production. It is now suggested by our New York contemporary, *Radio Craft*, that the term Appliqué should be used. The dictionary definition of appliqué is "work cut from one material and applied to the surface of another." Is there a more suitable term?

### RADIO REPORTING

CLOSE on the heels of the introduction of walkie-talkie equipment for newspaper reporting came the transmission of Press pictures by portable radio equipment. The photograph of the finish of the Oaks was in some London newspaper offices within a few minutes of being transmitted from the Epsom race-course some 17 miles away.

Kemsley Newspapers employed Muirhead-Belin portable gear in conjunction with Marconi E.H.F. communication equipment. The Muirhead set transmitted a picture 5½ in x 8 in at 135 lines per inch. It took eleven minutes to complete. The output from the photo-scanner was fed directly into the standard E.H.F. communication transmitter. In the case of the *Evening Standard* a Belin (French) picture transmitter was used with Pye communication gear.

### BIRTHDAY HONOURS

Among the recipients of Honours is R. J. Dippy, senior principal scientific officer, Ministry of Supply, who is appointed an O.B.E. He was responsible for the development of Gee and is now concerned with the application of radar to civil aviation.

Lt. Col. W. French, D.S.O., M.C., superintendent, Technological Department, City and Guilds Institute, and W. F. Higgins, O.B.E., M.Sc., superintendent Physics Division, N.P.L., are appointed C.B.E.s.

Among the members of the radio industry honoured are G. E. Condliffe, director, E.M.I. Research Laboratories, who is appointed an O.B.E., and L. H. Hayward, chief inspector, Kolster Brandes; D. H. Perkins, chief development engineer, Henry Hughes and Son; and G. M. Tomlin, chief development engineer Salford Electrical Instruments, who become M.B.E.s.

The British Empire Medal was awarded to A. Bickham, radio overseer, R.A.F. Southern Signals Area, and J. D. Wynne, M.M., radio operator, P.O. Portishead Radio Station.

### PERSONALITIES

Dr. J. H. Dellinger, of "Dellinger Effect" fame, who had been chief of the Central Radio Propagation Laboratory of the U.S. National Bureau of Standards, retired on April 30th. He had been in Government service for forty years. He is U.S. representative on the International Provisional Frequency Board (Geneva) and is president of the Standards and Measurements Commission of the Union Radio Scientifique Internationale.

G. L. Stephens, who had been in the engineering branch of the Post Office for many years, has joined Belling and Lee's staff of suppression engineers.

William J. Lloyd, B.Sc., A.M.I.E.E., has resigned his position as chief engineer of Tannoy Products and is now undertaking consulting work. His address is Matching Vicarage, Harlow, Essex.

### IN BRIEF

**Receiving Licences.**—An increase of 3,650 was recorded in the number of television licences issued at the end of April. The total was 49,200. The number of broadcast receiving licences was approximately 11,236,450.

**Radio and Shipping.**—A Radio Advisory Service has been established jointly by the Chamber of Shipping and the Liverpool Steam Ship Owners' Association for the purpose of making available to individual firms an advisory service on radio. The service will be directed by Capt. F. J. Wylie, R.N. (retd.), who has successively held the Admiralty posts of Deputy Director



300-FOOT tower recently completed at the Federal Telecommunications Laboratories of the International Telephone and Telegraph Corporation at Nutley, N.J., U.S.A. It will be used for investigating U.S.W. propagation.



of the Signal Department (1941-1943) and Director of Radio Equipment (1944-46).

**Suppressing Interference.**—A correspondent tells us that his gift of suppressors to his neighbours whose cars mar his television reception has been warmly received. In some cases the recipients did not know how severely they interfered with television until they were given a demonstration. A recent addition to the rapidly lengthening list of big companies fitting suppressors to their vans is T. Wall and Sons, the ice-cream and sausage manufacturers, whose 500 vans and cars have been suppressed.



—the U.S.A. Known as the Wireway recorder it weighs only 22½ lb.

**Scientific Liaison Offices.**—To facilitate the exchange of information and the co-operation between scientific organizations within the Commonwealth, scientific liaison offices have been opened in London. The British Commonwealth of Nations Scientific Liaison Offices (B.C.S.O.), which have been established in Africa House, Kingsway, London, W.C.2 (Tel.: Holborn 3422), will include representatives from Australia, Canada, Central Africa, India, New Zealand, Pakistan, South Africa and the U.K. The liaison office of each country will be autonomous.

**Radio for Motor Racing.**—Another application of "business radio" was licensed by the Postmaster General for the maintenance of two-way communication between drivers and their base during the Isle of Man motor racing in May. Pye amplitude-modulated E.H.F. equipment, weighing only 40 lb, was installed in three of the competing cars, with a master station in the pits.

An interesting booklet has been prepared by Cable and Wireless, Ltd., giving some details of the services provided by the company. Its twenty-six pages are well illustrated and give, *inter alia*, a brief summary of the development of photo-teleggraphy.

**Schools' Equipment.**—A list of broadcast receiving equipment approved as suitable for use in schools has been issued by the School Broadcasting Council. All the listed apparatus has been tested by the Council and is classified as (a) apparatus specifically designed for schools and (b) sets designed primarily for domestic use but suitable for schools. The list is obtain-

able from the Council, 55, Portland Place, London, W.1.

**School of Electronics.**—The Ministry of Supply has opened a School of Electronics at T.R.E., Malvern. Two classes of students are being accepted: craft apprentices (selected locally) and engineering (professional) apprentices, selected by competitive exam.

**I.E.E. Students.**—Membership of the London Students' Section of the I.E.E. is given in the annual report for the 1947-48 session as 3,534, which is an increase over the previous year of nearly 200. Of the total, 2,406 are students, the remainder being graduates.

COMBINATION wire recorder-reproducer and disc reproducer which has been produced in—



**Institute of Physics.**—In the twenty-eighth annual report of the Institute the membership is shown to have increased by some ten per cent and is now 3,268. Of this total, 223 belong to the Electronics Group and 90 to the Electron Microscopy Group. The scope of the Institute's *Journal of Scientific Instruments* has been widened and the title modified to *Journal of Scientific Instruments and of Physics in Industry*.

**Architectural Acoustics.**—A three-day international conference on "Noise and Sound Transmission" has been organized jointly by the Acoustics Group of the Physical Society and the Royal Institute of British Architects. It will be held from July 14th to 16th in the Jarvis Hall of the R.I.B.A., 66, Portland Place, London, W.1. Contributions will be made by representatives from the U.S.A., France, Switzerland, Holland, Denmark, Germany and this country. Further details are available from the Acoustics Group, Physical Society, 1, Lowther Gardens, London, S.W.7.

**Engineering Course.**—A new two-year course in telecommunications engineering is starting at the Norwood Technical College next September. Students will have some practical experience with manufacturers of telecommunication equipment during the course, which leads to the City and Guilds Final Certificate Examination in Telecommunications Engineering. Students must be over sixteen and have a School Certificate with credits in English, mathematics and physics. Full particulars are obtainable from the Principal, Norwood Technical Col-

SOUND INSTALLATIONS  
in  
**Sports  
Arenas**  
CALL FOR THE  
**CLARITY**  
of  
**TRIX**  
Quality  
**SOUND EQUIPMENT**

Clear, undistorted output, efficiency in operation, robust construction and complete reliability are features of TRIX Sound Equipment which have led to its installation in Sports Arenas, Rinks, Dance Halls etc. all over the country.

In the entire range there is Sound Equipment not only for Sports Arenas but for every purpose and every type of installation from a 500 watt rack outfit to a portable battery model. A list giving full details will be gladly sent on request.

**SOME TRIX INSTALLATIONS**

Queen's Ice Rink, London.  
Richmond Ice Rink.  
Gateshead Greyhound Stadium.  
Mayfair Hotel, London.  
Cricklewood Dance Hall.  
Sportsdrome, Twickenham.  
Victoria Ballroom, Nottingham.  
State Opera House, Ankara, Turkey.  
and many Theatres, Restaurants, Clubs, etc

**THE TRIX ELECTRICAL CO. LTD.**  
1-5 Maple Place, Tottenham Court Road,  
London, W.1. Phone: MU5eum 5817.  
Grams & Cables: "Trixradio, Wesdo, London."

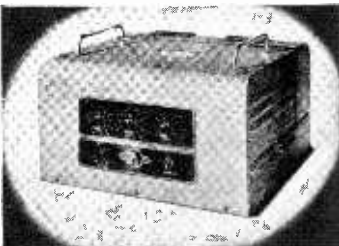

30-watt Amplifier: Model T 633 B

AMPLIFIERS • MICROPHONES • LOUSPEAKERS

## World of Wireless—

Jege, Knights Hill, London, S.E.27 (Tel.: Gipsy Hill 2268).

**Electronics Exhibition.**—The Third Annual Electronics Exhibition organized by the North-West Section of the Institution of Electronics will be held at the College of Technology, Manchester, during the three days July 20th-22nd. There will also be an exhibition of scientific films arranged by the Manchester Scientific Film Society. Admission will be by ticket, obtainable from Dr. J. A. Darbyshire, 1, Kershaw Road, Failsworth, Manchester.

## FROM ABROAD

**German Licences.**—The number of licensed listeners in the British Zone of Germany in March had increased by 41,827 over the previous month, to 3,225,806. According to the O.I.R. the total includes 127,871 licence holders living in the U.S.-controlled Bremen conclave.

**F.M. in Italy.**—The Italian broadcasting authority, Radio Audizioni Italiano, is installing a 3-kW experimental F.M. transmitter for the forthcoming Milan Fair. It will radiate on 99.8 Mc/s. Similar transmitters are to be erected in Rome and Turin.

**Putting F.M. on the Map.**—In the past F.M. stations in the United States have been granted experimental licences for one year only. The Federal Communications Commission now states that "the rapid development of F.M. merits the statutory maximum licence period." Stations will in future be granted three-year licences.

**Citizen's Radio transceivers** have been approved by the F.C.C. and are being produced in the United States by the Citizens' Radio Corp. of Cleveland, Ohio. The set, which operates on 465 Mc/s, weighs approx. 2½ lb.

**Eire's S.W. Station,** which was recently completed but has not yet been used, is to be sold. The Minister of Posts and Telegraphs stated that the main reason for the decision was economy. The cost of radiating short-wave programmes for but two hours a day would be some £50,000 a year.

**U.S.S.R. Amateurs** held a national exhibition in Moscow at the end of May. The exhibits were selected from equipment shown at exhibitions held in seventy-four centres of the U.S.S.R.

## INDUSTRIAL NEWS

**British Dielectric Research, Ltd.,** is the name of a new company formed jointly by B.I. Callender's Cables, T.C.C. and United Insulators, for fundamental research in dielectrics. Laboratories are to be opened in N.W. London.

**Television Accessories.**—A new pre-amplifier utilizing the Mullard EF42 has been produced by Newhalk British Industries, 69, Hornsey Road, London, N.7. The gain is 25 db and the bandwidth is flat between 41 and 48 Mc/s. For districts where a high aerial gain is essential, a four-element array de-

signed to reduce interference and ghosts is also available.

**Solon electric soldering irons** are now available for voltages from 100 to 130 in addition to the standard 200 to 230. The lower voltage ranges are, of course, primarily for export. Models are available for 65, 125 and 240 watts.

**British Insulated Callender's Cables, Ltd.,** announces that its works at Leigh will be closed for the annual holidays

from July 3rd to 10th inclusive. The works at Prescot, Helsby and Willenhall will be closed from July 24th to August 2nd inclusive. Erith Works, Belvedere, Kent, will not be closed as holidays will be staggered.

**Audix B.B., Ltd.,** makers of school radio and gramophone equipment, have moved to Hockerill Works, Bishop's Stortford, Herts, where all correspondence should be sent. A London office will be opened shortly.

## New International Call Signs

**I**n our review of the "Final Acts" of the Atlantic City Telecommunications Conferences (April, 1948) reference was made to the changes in the international list of call signs.

Although the complete list will not become effective until the provisions of the Convention, signed by the delegates of the seventy-eight participating countries, come into operation on January 1st, 1949, the changes are already being made.

The Atlantic City Radio Regula-

tions stress the fact that it is not compulsory to assign call signs from the international series given below to radio-telephone and other stations which are easily identified by their names and whose signals of identification are published in the official list. It is, however, stressed that when a broadcasting station uses more than one frequency in the international service each frequency must be identified by a separate call sign or by some other appropriate means.

Call Signs.	Country.	Call Signs.	Country.	Call Signs.	Country.
AAA-ALZ	U.S.A.	JAA-JSZ	Japan.	XPA-XPZ	Denmark.
AMA-AOZ	(Not allocated).	JTA-JVZ	Mongolia.	XQA-XRZ	Chile.
APA-ASZ	Pakistan.	JWA-JXZ	Norway.	XSA-XSZ	China.
ATA-AWZ	India.	JYA-JZZ	(Not allocated).	XTA-XWZ	France and Cols.
AXA-AXZ	Australia.	KAA-KZZ	U.S.A.	XXA-XXX	Portuguese Cols.
AYA-AZZ	Argentina.	LAA-LNZ	Norway.	XYA-XZZ	Burma.
BAA-BZZ	China.	LOA-LWZ	Argentina.	YAA-YAZ	Afghanistan.
CAA-CEZ	Chile.	LXA-LXZ	Luxembourg.	YBA-YHZ	Netherlands
CFA-CKZ	Canada.	LYA-LYZ	Lithuania.		Indies.
CLA-CMZ	Cuba.	LZA-LZZ	Bulgaria.	YIA-YIZ	Iraq.
CNA-CNZ	Morocco.	MAA-MZZ	Great Britain.	YJA-YJZ	New Hebrides.
COA-COZ	Cuba.	NAA-NZZ	U.S.A.	YKA-YKZ	Syria.
CPA-CPZ	Bolivia.	OAA-OZZ	Peru.	YLA-YLZ	Latvia.
CQA-CRZ	Portuguese Cols.	ODA-ODZ	Lebanon.	YMA-YMZ	Turkey.
CSA-CUZ	Portugal.	OEA-OEZ	Austria.	YNA-YNZ	Nicaragua.
CVA-CXZ	Uruguay.	OFA-OFZ	Finland.	YOA-YRZ	Rumania.
CYA-CZZ	Canada.	OKA-OMZ	Czechoslovakia.	YSA-YSZ	El Salvador.
DAA-DMZ	Germany.	ONA-OTZ	Belgium and Cols.	YTA-YUZ	Yugoslavia.
DNA-DOZ	Belgian Congo.			YVA-YYZ	Venezuela.
DRA-DTZ	Bielorussia.	OUA-OZZ	Denmark.	YZA-YZZ	Yugoslavia.
DUA-DZZ	Philippines.	PAA-PIZ	Netherlands.	ZAA-ZAZ	Albania.
EAA-EHZ	Spain.	PJA-PJZ	Curaçao.	ZBA-ZJZ	British Cols.
EIA-EJZ	Ireland.	PKA-POZ	Netherlands	ZKA-ZMZ	New Zealand.
EKA-EKZ	U.S.S.R.		Indies.	ZNA-ZOZ	British Cols.
ELA-ELZ	Liberia.	PPA-PYZ	Brazil.	ZPA-ZPZ	Paraguay.
EMA-EOZ	U.S.S.R.	PZA-PZZ	Surinam.	ZQA-ZOZ	British Cols.
EPA-EQZ	Iran.	QAA-QZZ	(Abbreviations).	ZRA-ZRZ	South Africa.
ERA-ERZ	U.S.S.R.	RAA-RZZ	U.S.S.R.	ZVA-ZZZ	Brazil.
ESA-ESZ	Estonia.	SAA-SMZ	Sweden.	2AA-2ZZ	Great Britain.
ETA-ETZ	Ethiopia.	SNA-SRZ	Poland.	3AA-3AZ	Monaco.
EUA-EUZ	U.S.S.R.	SSA-SUZ	Egypt.	3BA-3FZ	Canada.
FAA-FZZ	France and Cols.	SVA-SZZ	Greece.	3GA-3GZ	Chile.
GAA-GZZ	Great Britain.	TAA-TCZ	Turkey.	3HA-3UZ	China.
HAA-HAZ	Hungary.	TDA-TDZ	Guatemala.	3VA-3VZ	France and Cols.
HBA-HBZ	Switzerland.	TEA-TEZ	Costa Rica.	3WA-3XZ	(Not allocated).
HCA-HDZ	Ecuador.	TFA-TFZ	Iceland.	3YA-3YZ	Norway.
HEA-HEZ	Switzerland.	TGA-TGZ	Guatemala.	3ZA-3ZZ	Poland.
HFA-HFZ	Poland.	THA-THZ	France and Cols.	4AA-4CZ	Mexico.
HGA-HGZ	Hungary.	TIA-TIZ	Costa Rica.	4DA-4IZ	Philippines.
HHA-HHZ	Haiti.	TJA-TJZ	France and Cols.	4JA-4LZ	U.S.S.R.
HIA-HIZ	Dominican Rep.	UAA-UOZ	U.S.S.R.	4MA-4MZ	Venezuela.
HJA-HKZ	Colombia.	URA-UTZ	Ukraine.	4NA-4OZ	Yugoslavia.
HLA-HMZ	Korea.	UUA-UZZ	U.S.S.R.	4PA-4SZ	British Cols.
HNA-HNZ	Iraq.	VAA-VGZ	Canada.	4TA-4TZ	Peru.
HOA-HPZ	Panama.	VHA-VNZ	Australia.	4UA-4UZ	United Nations.
HQA-HRZ	Honduras.	VOA-VOZ	Newfoundland.	4VA-4VZ	Haiti.
HSA-HSZ	Siam.	VPA-VZZ	British Cols.	4WA-4WZ	Yemen.
HTA-HTZ	Nicaragua.	VTA-VWZ	India.	4XA-4ZZ	(Not allocated).
HUA-HUZ	El Salvador.	VXA-VYZ	Canada.	5AA-5ZZ	(Not allocated).
HVA-HVZ	Vatican City.	VZA-VZZ	Australia.	6AA-6ZZ	(Not allocated).
HWA-HYZ	France and Cols.	WAA-WZZ	U.S.A.	7AA-7ZZ	(Not allocated).
HZA-HZZ	Saudi Arabia.	XAA-XIZ	Mexico.	8AA-8ZZ	(Not allocated).
IAA-IZZ	Italy and Cols.	XJA-XOZ	Canada.	9AA-9ZZ	(Not allocated).

# Short-wave Conditions

May in Retrospect: Forecast for July

By T. W. Bennington and L. J. Prechner (Engineering Division, B.B.C.)

**DURING** May the average maximum usable frequencies for these latitudes decreased considerably during the day, and remained at the same level as in April during the night. The night values were therefore lower than expected from the normal seasonal trend, but April night values were probably high owing to abnormal sunspot activity in that month.

Communication on frequencies higher than 35 Mc/s was very infrequent. Contact was maintained on the 28 Mc/s band with North America and New Zealand for part of the month, and with South Africa for most of the month. Conditions on the lower frequencies were poor, atmospheric being very heavy. Frequencies below 14 Mc/s for distances over 3,000 miles were seldom usable at night.

As predicted, Sporadic E transmission occurred more often and many contacts were made with the Continent on the 28 Mc/s band.

The Paris television transmissions (sound 42 Mc/s, vision 46 Mc/s) were received in Southern England on a number of occasions. This reception, well beyond the optical range, may have been perhaps due to the weather conditions in May causing, at times, abnormal tropospheric propagation.

Although the sunspot activity was less in May than in the almost record month of April, considerably more ionospheric storminess was observed in May than in April. Ionosphere storms occurred on 2nd-3rd, 7th-9th, 11th-13th, 15th-17th, 21st-25th, 28th and 30th, those of the 2nd, 13th, 16th and 22nd-23rd being particularly severe. These may have been probably due to sunspot activity as six fairly large sunspots were observed in May. Four of them, all in southern solar latitudes, crossed the central meridian in a relatively short period between May 10th and 15th.

Many "Dellinger" fade-outs have been observed, those on 5th, 6th and 21st being outstanding in severity.

**Forecast.**—It is expected that there should be very little difference between the M.U.F.s for July and June, as the seasonal trend in the Northern Hemisphere is for the daytime and night-time M.U.F.s to reach in this period their annual minimum and maximum values respectively.

As in June, daytime communication on very high frequencies (like the 28 Mc/s band) is not likely to be very frequent, but over many circuits fairly high frequencies, like 17 Mc/s, will remain regularly usable till midnight. During the night frequencies lower than 11 Mc/s will be seldom required, and 15 Mc/s may remain usable throughout the night on many circuits.

For medium distances—up to about 1,800 miles—the E or F1 layers will control transmission for considerable periods during the day. In such cases daytime as well as night-time frequencies should be higher than in May.

Sporadic E is usually very prevalent in July, and so on many occasions (which it is however impossible to predict) communications over distances up to 1,400 miles may be possible by way of this medium on frequencies greatly in excess of the M.U.F.s for the regular E and F layers. For example, frequencies as high as 60 Mc/s may be occasionally reached for a very short time.

Below are given, in terms of the broadcast bands, the working frequencies which should be regularly usable during July for four long-distance circuits running in different directions from this country. In addition, a figure in brackets is given for the use of those whose primary interest is the exploitation of certain frequency bands, and this indicates the highest frequency likely to be usable for about 25 per cent of the time during the month for communication by way of the regular layers:—

<b>Montreal :</b>	0000	15 Mc/s	(19 Mc/s)
	0200	11 "	(15 " )
	1200	15 "	(19 " )
<b>Buenos Aires :</b>	0000	17 Mc/s	(22 Mc/s)
	0100	15 "	(19 " )
	0700	11 "	(16 " )
	1000	17 "	(25 " )
	1400	21 "	(27 " )
<b>Cape Town :</b>	0000	17 Mc/s	(22 Mc/s)
	0100	15 "	(19 " )
	0500	17 "	(24 " )
<b>Chungking :</b>	0800	21 "	(27 " )
	2100	17 "	(23 " )
	0000	11 Mc/s	(16 Mc/s)
	0400	15 "	(19 " )
	2200	11 "	(16 " )

Ionosphere storms are not usually very prevalent during July, but at the time of writing it would appear that the most likely periods during which disturbances may occur are 1st-4th, 9th-10th, 13th-15th, 23rd-24th and 27th-31st.



**NEW!**

**AUDIO FREQUENCY CHOKE** 9 kcs to 20 kcs adjustable, as used on high quality infinite impedance detector circuits. Price 7/6. Diagram supplied.

## NEW CIRCUIT

**5 VALVE WIDE-BAND SUPERHET RECEIVER** for the reception of the B.B.C. transmissions on 90 mcs. Full size Blue Prints, practical and theoretical, price 7/6.

**CIRCUIT No. 20.** 10 valves, 6 wave-bands, 12 watts (undistorted) Output Superheterodyne Receiver. Owing to the excellent reports we have received to the above we are devoting our space this month to another description of it. Constructed from our No. 20 Brief specification. R.F. stage of Amplification using 6K7 H.F. Pen., the gain of which is controlled, followed by F.C. Triode Hexode 6K8 followed by I.F. Amp. stage 6K7 feeding into a double diode triode 6Q7 for L.F. Amp. and 2nd detector and noise limiter, followed by phase inverter feeding 2-6V6 or 2-6L6 in push pull. Rectifier valve 5U4G. Visual tuning indicator (Magic eye EM34).

**The Coil Unit.** The coil unit consists of 18 high "Q" iron cored coils, 6 each in R.F., H.F. and Osc. stages, all midget type, designed especially for us. 20 Ceramic trimmers and 3 bank switch, with shorting plates.

A.V.C. is used on all wave-bands with a switch for cutting out when not required. The coil unit is completely screened by 18 s.w.g. aluminium. The output transformer is of multi-ratio type mounted under the chassis. Controls R.F. gain, 6-wave-band coil switch, A.V.C. on/off radio-gram switch, noise limiter, tone-control, Audio gain and mains on/off. Provision for B.F.O. on/off if required.

3 gang tuning condenser rubber mounted. Slow motion drive and 6 wave band dial, Chassis 16 s.w.g. Aluminium, ready drilled 12½ × 7½ × 4.

3 Fuses fitted 2 in mains supply and 1 in rectifier circuit.

Provision for dipole Aerial, extension speaker and P.U. sockets.

This set is noted for its fine quality of reproduction on radio and gram. We have received much appreciation and congratulations from customers on its performance. A demonstration model is available at our premises at 307, High Holborn, London, W.C.1.

**Full Size Blue Prints** (2 practical and 1 theoretical) and priced list of components price 6/-.

**6-Valve Superhet Circuit,** 3 wavebands. A/C only. **A circuit that will please the most critical.** This circuit has been designed to receive all worthwhile stations on the medium wave band (200-540 metres) with a high fidelity output. Short waves (16-47 metres) are as good as obtained on some purely short-wave receivers. Australia and America have been received regularly by many of our customers at loudspeaker strength. Long Wave: The few stations now operating are well received. Blue Prints: 2 practical and 1 theoretical with detailed priced list of components, priced 5/- per set.

**307, HIGH HOLBORN.**  
LONDON W.C.1. Phone: HOLborn 4631



# Unbiased

By FREE GRID

## Tuning Tests for All

I WAS more than glad to read the Editor's *ex cathedra* utterance last month in which he expressed grave doubts about the advisability of the B.B.C. going on with its projected plans for a chain of E.H.F. stations using frequency modulation without first undertaking a further series of experiments with amplitude modulated E.H.F.

One of the reasons why I am glad is that I am able to set at least one of his doubts at rest, namely the one about tuning an F.M. set about which he says "it is doubtful whether the ordinary listener will be able to adjust his set with sufficient accuracy." If the Editor could combine what the poet calls "The warmth of human companionship" with his academic achievements and move about freely among the people, as I do, he would soon learn that there is no doubt about the matter at all. Anyone with the slightest ear for music will soon realize this by taking a stroll down



Suburban Stridor.

any suburban street on these lovely summer afternoons when the loudspeakers are making life hideous by bellowing like the bulls of Bashan from wide-flung windows.

Almost without exception the woman-tuned receivers driving the loudspeakers are working on the edge of the sidebands. The hideous rasping and rattling noise produced sets all the menfolk running at top speed as they near their houses in the evening so that they can end the

racket by tuning the set properly. Only in cases where a push-button set is installed are these teeth-on-edge sibilations absent in the daytime when wireless receivers are at the mercy of our ham-handed Harriets. Many a time this cacophonous caterwauling, grating upon the sensitive ears of a passing Romeo, must have made him realize that marriage has its darker side.

I have yet to meet the woman who can tune a wireless set properly. Now if they are incapable of tuning a straightforward A.M. set, they will certainly make a hopeless hash of an F.M. set. Since, as I have endeavoured to point out, it is the women who do most of the knob twiddling, I warmly support the Editor's suggestion that the B.B.C. should pause before embarking upon an uncharted sea of F.M. The only alternative is to bring wireless-set tuning into line with car driving and make everybody pass a stiff tuning test before a wireless licence is issued to them.

This would be to the ultimate advantage of all and the immediate advantage of many such as the proprietors of the various wireless schools and colleges who would naturally undertake the instructional work.

## The Ether Must Go

THERE are two main schools of thought concerning the cause of the Earth's axial rotation, namely, love and the initial spin given to our planet when it was torn from the bosom of its mother star, the sun, by the too-near approach of another star. The latter is, of course, one of the many theories that is, or has been at one time, favoured by certain of the astronomical fraternity. I'm sure I don't know what particular theory is fashionable nowadays at Greenwich. Whatever it is, it is a fairly safe bet that, like the New Look, it will eventually be discarded as indeed should all scientific hypotheses when they have outlived their usefulness and been shown to be no longer tenable.

Unfortunately, however, this doesn't seem to apply to our own particular branch of science where the ether lingers on long after it has served its turn rather like the smell of its physical namesake in a disused operating theatre. The radio writers

whose cerebral emanations are intended for readers of a more elementary standard than *W.W.* subscribers still seem to be stalwart champions of the idea that the ether has a real objective existence like beer. They lead their disciples to invite the attentions of the Commissioners in Lunacy by dropping stones into ponds and suchlike analogical anachronisms.

I doubt if any present-day radio man supposes the ether to have any physical existence although at one time the hypothesis of its existence undoubtedly helped us to understand certain things, just as the two-fluid theory assisted a bygone generation



The New Look.

of scientists to account for electrical phenomena until several nasty little facts failed to fit in with it and caused them to discard it.

Maybe the Editor or some of his technical satellites may resent any attack on the ether. If so, nobody will be more pleased than me to receive references to authoritative books or other writings which will prove that it does really exist in more tangible form than Sairey Gamp's elusive friend Mrs. Harris. I don't want out-of-date reference, otherwise I shall counter attack by producing an excellent manual in which a worthy prelate who was also a poet provides some very striking arguments in favour of his theory that it is love which makes the world go round.

Perhaps I am all wrong and there has been a recrudescence of etheric thinking as a result of recent developments in things like nuclear physics and paranormal emanations. At any rate I will now stand aside while Counsel for the Defence addresses you after which the Editor will sum up and according to your verdict, pass sentence of death or release the ether without a stain on its character. More likely, however, he will with customary editorial caution bind the ether over to come up for judgment whenever called upon to do so.

## LETTERS TO THE EDITOR

### Standardization of Valves ♦ Sound Reflectors ♦ Television Interference ♦ Direct-coupled Amplifier ♦ E.H.F. Broadcasting

#### Valve Standardization

IT has been stated that exporters find it increasingly difficult to keep up the £M-per-month exports of radio gear which they have been achieving during the last 15 or 20 months.

I think at least one reason is the obvious inability of the British valve industry to work out a thorough standardization of types. As far as I can make out all we have got out of endless talks are 3 new valve bases, for which there is not the slightest justification, added on to the already inflated number of bases in use or obsolete.

I cannot but feel sympathetic towards foreign buyers who think twice before ordering British radio equipment, as they have to consider the additional stocking up necessary to deal with valve replacements.

In my opinion the intransigence of certain valve manufacturers will, before long, be an open invitation to the Government to step in and impose standardization.

K. E. MARCUS.

Uxbridge, Middlesex.

#### Artificial Acoustic Reflectors

I WAS very interested to read the remarks of Desmond Roe on the subject of sound reflectors in your March issue.

We carried out a number of experiments on the same lines as Mr. Roe some 10 years ago, and we have in fact used large sheets of corrugated material for high fidelity demonstrations in the past.

For the best performance a good reflecting surface must of course be used, and the corrugations should be of larger dimensions than those used by Mr. Roe. The whole sheet should be slightly curved, depending on the distance of the loudspeaker. In practice, the loudspeaker should be between 5 and 6ft away from the reflector and no diffusion at the loudspeaker should be neces-

sary. The loudspeaker should point diagonally towards the reflector, and it is usually necessary to make some arrangements to prevent some direct sounds being heard from the loudspeaker.

The effect of the above falls mainly under four headings:—

- 1.—Good sound dispersion.
- 2.—Elimination of point source.
- 3.—An increase of distance for direct sound.
- 4.—The polar diagram response of the loudspeaker is integrated (as distinct from the dispersion of axis response).

All of these points are of importance and add very considerably to "presence" in reproduction. Since large corrugated reflectors are not always practical in the home, efforts must be made to achieve the results in a more practical form. Unfortunately the size of any reflector must be comparable to the wavelength of the sound which it is to reflect, and this represents the greatest difficulty.

P. J. WALKER.

Acoustical Mfg. Company,  
Huntingdon.

#### Parasitic Oscillations

TO those constructors of the "Williamson" amplifier (*Wireless World*, April, 1947) who find that the addition of a tone control or feeder unit results in an oscillation at RF being radiated, I suggest the fitting of a grid stopper to  $V_1$  of the amplifier.

H. O. HUMPHREYS.

Monmouth.

#### Against Super - regeneration

NOW that so many home constructors are building their own television receivers, I think it would serve us all well to give sufficient publicity to the discouragement of the use of experimental sound receivers of the super-regenerative type.

Until he was located and the error of his ways pointed out to him, an innocent local amateur

The following figures are the pass figures on final test for  
**Model QA12/P**  
**AMPLIFIER**



FREQUENCY RANGE  
± 0.3 db 20 — 20,000 c.p.s.  
SENSITIVITY  
1.5 millivolts for full output  
(without boosts)  
15 millivolts for full output  
(with boosts)  
BASS CONTROL RANGE  
— 12 db to + 16 db at 30 c.p.s.  
relative to 600 c.p.s.  
TREBLE CONTROL RANGE  
— 30 db to + 18 db at 15,000  
c.p.s. relative to 600 c.p.s.  
DISTORTION CONTENT  
(up to 12 watts output)  
2nd Harmonic <0.2%  
3rd Harmonic <0.3%  
Higher order <0.03%  
Total <0.4%  
BACKGROUND NOISE  
better than — 66 db at full gain  
12  
DAMPING FACTOR  
INPUT IMPEDANCE  
1.5 megohms  
SOURCE IMPEDANCE  
Up to 50,000 ohms  
OUTPUT IMPEDANCE  
7 and 15 ohms

2262

**ACOUSTICAL**  
ACOUSTICAL MANUFACTURING  
CO., LTD., HUNTINGDON  
TEL : 361

**Letters to the Editor—**

television constructor almost a quarter-mile distant, using a dipole coupled to a super-regenerative sound receiver, rendered viewing almost completely impossible for a number of people for over a week.

E. J. WILLIAMS.  
Dagenham, Essex.

**Direct-coupled Amplifier**

THE accompanying diagram shows the circuit of my latest radio-gramophone amplifier.

To save your space I have not

a large condenser and connected to the H.T. supply through a large resistance, so that a flash represents the discharge of the condenser from the striking to the extinguishing voltage of the neon, and the interval between flashes is governed by the time required to recharge the condenser through the series resistance. The current consumed could probably be one-tenth or less of that required for continuous running of the neon. But the main snag with all neon schemes is that it is difficult to get neons to strike much below 90

ceiver we find it necessary to allow for several kilocycles drift 100 Mc/s. With normal receive bandwidths the "convert E.H.F." will normally be well out of tune, and the resulting distortion will be intolerable. Furthermore, the chief advantage E.H.F. is that a full audio-frequency range can be provided. The receiver used with a converter will not accept this range. A wide intermediate frequency band is essential if an effective noise limiter is to be used: this too you abandon in the converter scheme

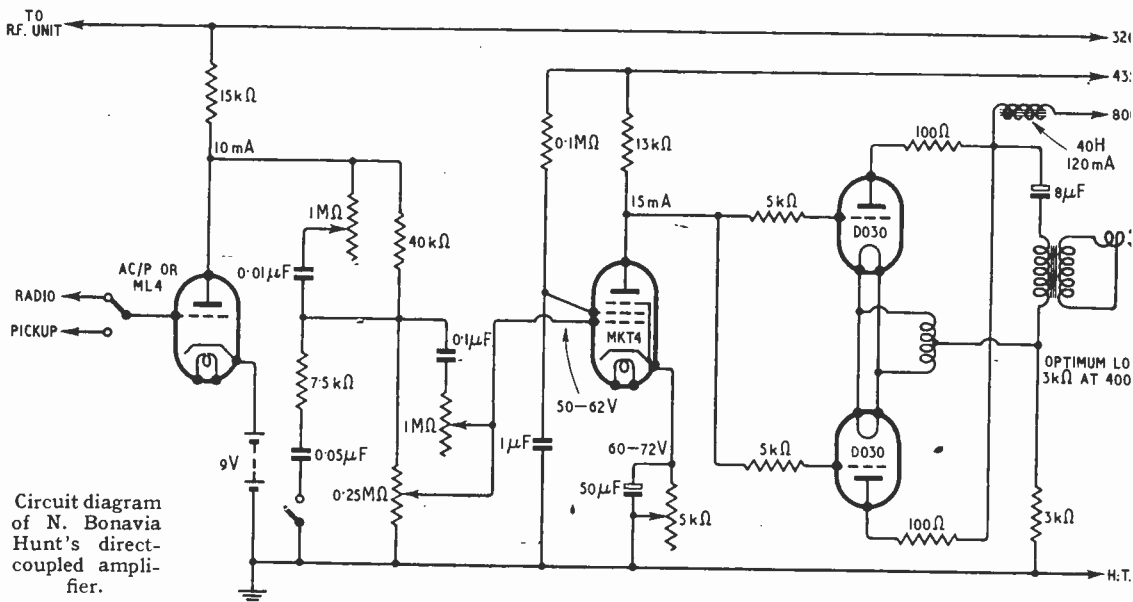

Circuit diagram of N. Bonavia Hunt's direct-coupled amplifier.

added any description of the circuit, but the diagram should speak for itself. This amplifier has been tested side by side with the best-known quality amplifiers in the hearing of a number of selected listeners, radio engineers and musicians so as to get a really impartial verdict, which was unanimously in favour of it. The measured frequency range is from 10 to 16,000 c/s.

N. BONAVIA-HUNT.  
Stagsden, Bedford.

**Indicators for Battery Sets**

IN your March issue, "Diallist" suggests the use of a neon lamp as indicator for battery sets. A still more economical indicator than a continuously running neon is a flashing neon (which I have seen mentioned in an American journal). The neon is shunted by

volts, and many battery sets are intended to continue working on lower voltages than this, even if the H.T. battery is 120V and not the newer 90V. The best indicator is a conspicuous "flag" in the tuning dial or elsewhere, and mechanically coupled to the on/off switch, but this needs good mechanical design.

D. A. BELL.  
Taplow, Bucks.

**E.H.F. Broadcasting**

MAY I suggest that the plan recommended in your June Editorial represents the surest way of damning amplitude modulated broadcasting at extra-high frequencies? The use of simple converters leads directly to two defects in reception: drift distortion and low quality. Even using crystal control in the re-

Let us face the facts: quality is expensive. F.M. can give the highest quality at the highest price: pulse modulation can give slightly poorer quality at a lower price: A.M. is cheap and nasty

THOMAS RODDAM.

**At a "Pre-war" Price**

A NEW superhet (Model 200) has been produced by Invict Radio, Parkhurst Road, London N.7, and will be sold for £9 9s (plus purchase tax). Covering medium and long waves, the set is housed in a bakelite cabinet and is for operation on A.C. or D.C. mains (200-250V). The Brimar 12K8GT frequency changer is followed by 12C8GT I.F. amplifier, A.V.C. detector and reflex A.F. amplifier, and the output stage is a 35L6GT. A 35Z4GT is used as the power rectifier.



## B.S.R.A. Conference and Exhibition

THE second annual conference organized by the British Sound Recording Association was held in London on May 29th and 30th, and members and guests enjoyed a very full and varied programme of events designed to cover the whole field of sound recording.

On Saturday, May 29th, after the annual general meeting, R. W. Lowden opened a discussion on disc recording and reproduction which included some remarkable micro-photographs of fibre, steel and sapphire points to show the effects of wear. On the question of loss of high frequency response near the centre of a record, it was emphasized that the radius of curvature of the waveform, which depended upon amplitude as well as frequency, was a safer guide to probable output than a comparison of wavelength with the radius of stylus tip. Considerable improvements in performance could often be obtained by adjusting for optimum needle track alignment at the centre instead of the middle or outside of the record.

Two papers were read on Sunday, May 30th. The first, by E. B. Angold, dealt with magnetic recording and reproduction, particularly from the point of view of the advantages and disadvantages of plastic tape and steel wire as recording media. Demonstrations were given of the two systems as exemplified in the American Brush "Soundmirror" tape recorder and the Brush BK303 wire recorder, the latter giving a playing time of over three hours with special wire having a plated magnetic alloy coating.

The second paper, read by D. Boston, on the factors involved in photographic recording on film, was illustrated by some recent recordings on 16 mm. film which showed that the limitations of linear speed inherent in this size of film did not preclude the recording of an acceptable standard of quality in music as well as speech.

A trade exhibition of recording equipment—probably the first of its kind in this country—was open throughout the conference and the exhibits included disc recorders by Bourne Instruments, Birmingham Sound Reproducers, E.M.I., Epsilon Research & Development Co., M.S.S. Recording Co. and Simon Sound Service; record changers and gramophone motors by Garrard, and pickups by Radio Instruments (Airtio) and A. R. Sugden (Connoisseur). Decca were showing a prototype electromagnetic cueing device capable of selecting accurately any part of any turn of the spiral groove of a record even when running eccentrically.

Examples of the latest Brush "Soundmirror" and "Magnetone" tape and wire recorders were shown by Thermionic Products, and Wirek Electronics had on view one of their Type 1 portable wire recorders. Modern film recording apparatus was demonstrated by British Acoustic Films.

### BOOKS RECEIVED

**Electric-motor Control Gear.**—By J. L. Watts, A.M.I.E.E. Deals in a practical way with the principles, arrangement and operation of the various types of gear now available for starting, protection and speed control. Pp. 83+xx; 79 illustrations. Published for *Electrical Review* by Iliffe and Sons, Ltd., Dorset House, Stamford Street, London, S.E.1. Price 5s; by post 5s 3d.

**Electrical Engineer Reference Book 1948.** Edited by E. Molloy, M. G. Say and R. C. Walker. A comprehensive summary of modern practice in all branches of electrical engineering; third edition, revised and extended. Pp. 1813, with many illustrations and diagrams. George Newnes, Tower House, Southampton Street, London, W.C.2. Price 42s.

**Crystal Rectifiers.**—By Henry C. Torrey and Charles A. Whitmer. Vol. 15 in the M.I.T. Radiation Laboratory Series. An account of the development of the modern crystal rectifier, mainly for use in frequency changers of radar and centimetre-wave equipment, during the war. Compiled principally from American sources. Pp. 443+viii; 218 illustrations. McGraw-Hill Publishing Co., Aldwych House, London, W.C.2. Price 36s in U.K.

### MANUFACTURERS' LITERATURE

Leaflet describing the "Philomel" radio-gramophone made by Ardente Acoustic Laboratories, Guildford.

Illustrated leaflet describing Type B4 signal generator, from Advance Components, Back Road, Shernhall Street, Walthamstow, London, E.17.

List of A.C. "Drilitic" capacitors for motor starting and other intermittent applications from Dubilier Condenser Co., Victoria Road, London, W.3.

Leaflet describing Model RH24 radio leader from Rediffusion, Broomhill Road, Wandsworth, London, S.W.18.

Catalogue of P.V.C. Thermoplastic Cables and Flexibles from the Telegraph Construction and Maintenance Co., 22, Old Broad Street, London, E.C.2.

Leaflet giving details of services offered—advisory, design, supply, information and technical publicity—from Electronic Applications Research Laboratories, Ayton Cottage, Matford Avenue, Exeter.

# HANDLES

immediate delivery



TYPE 10A.  
4" centres Fixed by two 2BA screws Chromium  
TYPE 10AA do Anodised Aluminium



TYPE 10C.  
6" centres Fixed by two 2BA screws Chromium  
TYPE 10CA do Anodised Aluminium



TYPE 7A.  
4" centres Fixed by four 4BA screws Chromium



TYPE 7E.  
8" centres Fixed by four 4BA screws Chromium



TYPE 15A.  
4" centres Fixed by two 4BA screws Chromium



TYPE 15C.  
6" centres Fixed by two 4BA screws Chromium



TYPE 12.  
6" overall Fixed by two 4BA screws Aluminium  
Anodised Silver or Colour



TYPE 11.  
8 3/4" overall Fixed by four 4BA screws Aluminium  
Anodised Silver or Colour

Here is a superb range of handles, styled in the modern manner, and ideally suited to numberless applications. These handles are easy to fit, fabricated in finest quality materials, and available for immediate delivery.

## INHOF'S

112-113, NEW OXFORD ST., LONDON, W.C.1.

# Random Radiations

By "DIALLIST"

## Television Progress

CONSIDERING ALL the handicaps (and they are many) with which it meets, television continues to forge ahead at a remarkable speed in this country. At the end of March, 1947, there were just over 14,500 licensed set owners; on the same date this year there were the best part of 45,000, which I make a 200 per cent increase in twelve months. What would the number be now if manufacturers could have obtained and used for the home market all the materials they wanted; if there were no purchase tax and if man-made interference had been slain at the proper place, its source? Another drag on the wheels that is not realized by everyone is that so many homes with mains electricity supplies receive "juice" of a kind unsuited to the televisor's constitution. You can make do with almost any A.C. voltage, so long as the frequency is 50c/s, by means of a suitable mains transformer. But, as yet, you can't do much with D.C., of which there's still a good deal in the London area, unless you go to the expense of installing a converter. And interference. Though the G.P.O., the B.B.C., the various radio industry association and many big firms, including the publishers of *Wireless World* have had all their motor vehicles suppressed, there still remain thousands of cars, vans and lorries on the roads which spread alarm and despondency in every television-equipped home that they pass during broadcasting hours. Since nearly all vehicles can be rendered innocuous for a shilling or two, without in any way affecting their performance, no injustice would surely be done to anyone if it were made illegal to own or drive an un-suppressed vehicle. Wouldn't it be within the powers of the P.M.G. to class all such cars, lorries and what-not as unlicensed transmitters of radio waves?

## A New Instrument Movement

THE FRENCH MAGAZINE *Toute la Radio* recently published an account of an entirely novel galvanometer movement, which seems to have possibilities. The chief claims are that it eliminates the comparatively large horse-shoe permanent magnet and the coiled return springs of the

familiar moving-coil type, so that it should be lighter, cheaper and more accurate. The current to be measured is fed to the windings of a toroidal coil which forms a segment of about 120 deg. Inside this moves a very light non-magnetic core. The core is concentric with the toroid and is attached by a light arm to a small vertical spindle, pivoted between bearings concentric with both coil and core. The spindle carries a pointer, which moves over a graduated scale. The core is provided with a tiny permanent magnet near one end and a little piece of soft iron near the other. Owing to their distance apart magnetic induction between permanent magnet and soft iron is negligibly small. When no current flows through the windings of the toroid the core and the pointer are free to move to any position. A minute current has negligible magnetizing effect on the soft iron but causes the permanent magnet to place itself at the geometric mid-point of the toroid. The pointer is then arranged to indicate zero on the scale. When the current reaches an intensity sufficient to magnetize the soft iron to the same degree as the permanent magnet the mid-point of the core sets itself at the mid-point of the toroid. This is the maximum position of the pointer. Between zero and maximum the position of the core and the pointer are governed by the intensity of the current. One can see several snags right away. With such an arrangement the zero is not really a zero but a minimum, for instance. Still, the idea has its attractive points and might be worth looking into.

## Miniaturization

TO JUDGE FROM the many articles that one sees on the subject in their radio publications, the Americans are going full ahead with the miniaturization of wireless equipment. Already some tiny "personal" receivers have been produced, and still smaller ones are projected. In fact, it looks as if the domestic receiver of to-morrow might be quite a small affair, little space being needed by its "rice-grain" valves, its printed circuits and its nickel-iron-cored A.F. transformers. But one can't see how it's going to be possible to produce acceptable quality for home reception from any kind of minia-

turized loudspeaker. It's wisest nowadays not to class anything in radio as impossible; the text books of twenty years ago and less flatly state the impossibility of not a few things which are commonplaces today. But I don't see how the loudspeaker business is going to be overcome. What will most likely happen in the next year or two is that genuine pocket receivers will make their appearance for use where and when quality is not an important consideration whilst the "fixed" home set remains of very much its present size. If you had all the miniature valves and other components that your heart might desire, could you see any way of producing a midget high-quality receiver?

## Naval Terminology

THE NAVY'S PROPOSAL to standardize the terms describing the various practical uses to which the longer electro-magnetic waves are put is distinctly attractive. At present "radio" and "wireless" are used as more or less interchangeable words in many quarters, though to the man in the street "wireless" is inclined to mean "broadcasting" and "radio" to signify telegraphy and telephony without the aid of wires. The Navy's suggested classification is sound: "radio" is, so to speak, the trunk of the tree from which spring main branches, such as "wireless," bearing the smaller branches "voice," "television" and "telegraphy." "Telegraphy" gives rise to the twigs "morse" and "teleprinter." If what is still just a suggestion becomes the official nomenclature and is adopted by the other Services, this common-sense classification may spread still more widely and should clear up a lot of the confusion that has so long existed in our radio terms. I'd like to see the frequencies used in radio similarly classified on a logical basis. At present one comes across such absurdities as low high frequencies, and high low frequencies. My suggestion is this: call the frequency received by the aerial the signal frequency, that at the output of the F.C. the intermediate frequency and that at the output of the detector the audio frequency. That would help a bit, but it still wouldn't get over the difficulty due to the fact that "high" and "low" are relative terms like "great" and "small." Just as we speak of a great big flea or a very small elephant, so we might describe the frequency of a 100-c/s mains supply as high and that of 55-Mc/s radar equipment as low. It would be ideal if every radio term meant one thing

and one thing only; but we've a long way to go before that happens. At what point, for example, if the frequency is steadily increased from 1 c/s, does a current cease to be alternating and become oscillating?

### Tropicalizing Equipment

SOME interesting observations regarding the proofing of radio equipment for use in tropical climates are given by a former Commandant of the "Tropical Testing Establishment," Ministry of Supply, Nigeria, in the *Technical Bulletin* of the Radio Component Manufacturers' Federation. He stresses the fact that constant temperatures of 85° to 90° with 100% humidity are registered in West Africa for 5 hours or so every day. Such humidity, which will make a bunch of keys completely rusty in a few days despite the fact that they are in constant use, spoils the action of switches, volume controls, etc., makes speaker cones "soggy" and causes corrosion and ultimate breakage of fine wire.

Complete airtight enclosure of all components is the ideal. This, however, is impossible but should be the aim as far as manufacturing conditions permit. Naked steel must not be used, of course, and even cadmium plating has been found to be unsatisfactory. Excellent protection is, however, provided by cellulosing, and the writer recommends the use of coloured metal cabinets rather than wood or plastic.

The fitting of a 5-watt strip heater in all mains sets is recommended. This should be permanently in circuit.

So far as the ravages of insects are concerned he recommends that ordinary wax-coated capacitors and resistors should be enclosed in metal cases and, as a further protection, the cardboard should be impregnated with a solution to ward off attacks by insects. Batteries should also be enclosed in metal cases and the cardboard impregnated.

Although not directly concerned with tropicalization the writer recommends that all mains sets should be fitted with constant voltage transformers to counteract the very large voltage fluctuations, sometimes between 165 and 250, met with in some areas.

### New Resistors

High-stability carbon resistors under the trade name of "Celco" are being produced by Cambridge Electrical Components, 21a, Union Lane, Cambridge. Values range from 10Ω to 10 MΩ and the elements are produced by a continuous high-vacuum process. Silicone varnish is used for waterproofing.

# BULGIN

REGISTERED TRADE MARK

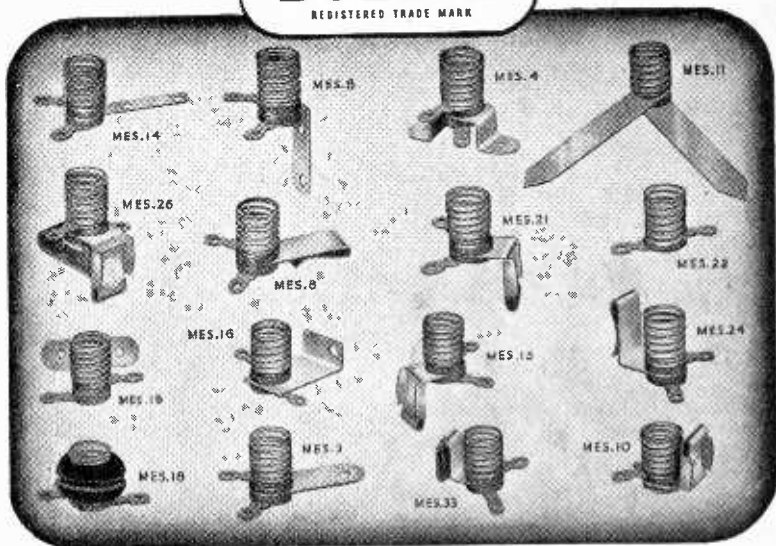

## M.E.S. LAMP HOLDERS

IN AN INCOMPARABLE RANGE OF CLIP OR BRACKET MOUNTS

MANUFACTURED in a wide range of types, BULGIN Pilot Lamp Holders accurately conform to B.S. 98/E. 10 (M.E.S.) for lamp-acceptance. The "shell" or socket, in every type, acts as one of the poles. Fitted with centre-contact leaf or plunger; all contacts and tags are silver-plated for easy and efficient connections. The various fixing brackets are not live to either pole. Tested at 500V. peak (= max. test V.) for insulation resistance of not less than 40MΩ dry. For use at 0.1 to 30V. across poles (250V. max. with seriesΩ), 250V. max. to E. Max. Current 2A.

Types with M.B.C. (B.S. 52) and S.E.S. (B.S. 98/E. 14) sockets can also be supplied.

Enquiries for direct—and indirect—export are particularly invited.

"The Choice

# BULGIN

REGISTERED TRADE MARK

of Critics"

A. F. BULGIN & CO. LTD. · BYE-PASS RD. · BARKING

Telephone : RIPpleway 3474 (5 lines)



# RECENT INVENTIONS

## A Selection of the More Interesting Radio Developments

### WAVES GUIDES

IT is sometimes required to attenuate or dissipate the power carried by a wave guide, without giving rise either to undesired radiation from the terminal point, or to disturbances reflected back along the wave guide due to abrupt change of impedance.

For this purpose the end section of the guide is tapered to a point by a sloping wall, which gradually decreases the internal transverse cross-section to a narrow opening, or to a closed point. One or more V-shaped apertures, each with its apex facing the feeding end of the guide, may also be cut in the walls, in order to secure a desired terminating impedance. The apertures may be covered by thick blocks of rubber, which is loaded with finely divided metal or graphite, in order to dissipate the energy uniformly and without radiation.

G. E. F. Fertel and C. S. Wright.  
Application date, August 3rd, 1944. No. 590651.

### TELEVISION SYSTEMS

THE picture signals are applied by phase or frequency modulation, whilst the line and frame synchronizing signals are applied by amplitude modulation of the same carrier wave, preferably so as to reduce the amplitude to zero.

One advantage is that the resulting wave can be passed through limiter stages at the receiving end, in order to remove any noise impulses or other extraneous disturbances tending to distort the picture, without in any way affecting the efficiency of the synchronizing signals. The system also prevents any casual triggering by such noise voltages of the synchronizing circuits in the receiver.

When relaying television programmes through a series of linked transmitters and receivers, at least one of the amplifiers in each receiver is biased so that no current can pass through during the occurrence of any synchronizing signal. This serves to offset the tendency of such systems to build up noise.

W. S. Percival. Application date, May 10th, 1945. No. 591707.

### CRYSTAL-CONTROLLED OSCILLATOR

ANY tendency of the crystal to generate harmonic frequencies is automatically offset by the introduction of negative feedback.

In the absence of the crystal Q, the circuit shown is not regenerative in

spite of the tuned circuit LCCr, since any change in anode potential will produce an in-phase change of grid potential. The introduction of the piezoelectric element will, however, set up sustained oscillations, which are automatically stabilized at the fundamental frequency because only at that frequency does the crystal behave as a resistance of low value. The negative feed back through the crystal is then dominated by the positive feed back through the tuned circuit. At harmonic frequencies the impedance of the crystal is high, and the resulting negative feed back is sufficiently strong to damp out the undesired mode of operation. Should the crystal become inactive, or be short-circuited, the circuit reverts to its original inert condition, and all oscillations immediately cease.

Standard Telephones and Cables, Ltd. (assignees of G. T. Royden), Convention date (U.S.A.) November 9th, 1943. No. 587319.

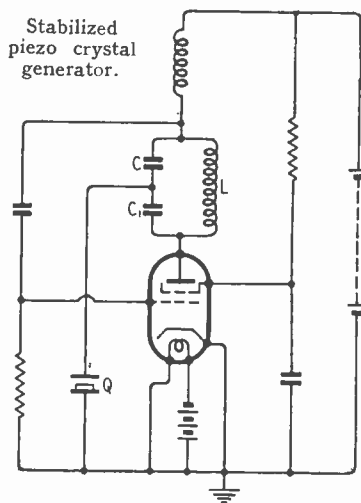

### BANDSPREAD TUNING

WHEN the wavechange switch of a superhet receiver is moved to the short-wave setting, the ordinary fixed coils in the preselector and oscillator circuits, respectively, are cut out and replaced by a corresponding pair of coils provided with moving cores to produce a bandspreading effect, which facilitates the accurate selection of stations.

On the long and medium waves, provision is made for manual or push-button tuning in the ordinary way. The short-wave range is divided into five sub-sections, and each of the auxiliary moving-core coils is shunted by a corresponding set of five fixed coils, which are of graded value and are under the control of the wavechange switch. On any of the short-wave settings the single control knob varies the tuning of the two main condensers as usual, and, in addition, rotates a cam which adjusts the position of the cores of the variable-permeability coils in the preselector and oscillator circuits. The graded

shunt coils provide the necessary adjustment between the various sub-sections of the complete short-wave range.

E. K. Cole, Ltd., L. W. D. Sharp and H. Hunt. Application date May 10th, 1945. No. 591706.

### DIVERSITY RECEPTION

IN order to minimize fading, it is customary to utilize at least three widely spaced aerials, and to combine the rectified signals from all of them in a common circuit, so as to maintain an effective signal strength at all times, in spite of periodic variations in the local phasing.

The object of the present invention is to secure substantially the same advantage by the use of only two spaced aerials. For this purpose each aerial is coupled in parallel to a pair of amplifiers, and the signals from one of each pair of amplifiers are separately rectified before being fed to a common load resistance. The signals from the remaining two amplifiers, both of which are, of course, coupled to different aerials, are first combined together before being passed to a third amplifier, which also feeds the common load resistance. The effective signal strength is thus maintained by the voltage picked up on each of the aerials individually, as well as by the voltage received simultaneously by both aerials. The second factor provides an additional safeguard against the normal risk of fading.

Marconi's Wireless Telegraph Co., Ltd. (assignees of W. I. Matthews). Convention date (U.S.A.) March 30th, 1944. No. 589898.

### ELECTRONIC SWITCHING

IN radar equipment using common aerial systems, it is necessary to close the receiving circuits against outgoing pulses, and to open them again in time to receive the reflected signals. This high-speed switching operation is usually controlled by gas-filled discharge tubes, which are triggered by each transmission. Unfortunately the argon gas filling of the tube tends to remain ionized for a short period after each discharge, and this may be sufficient to prevent the reception of short-range echoes.

It has been found that the presence of water vapour helps to speed-up the de-ionization of the gas in the tube. A permanent source of the vapour is accordingly provided in the form of a suitable hydrate, such as silica-gel. This is placed in a small metal gauze container, which is enclosed in the glass bulb during manufacture. The container is surrounded by a freezing mixture during the evacuation of the bulb, in order to prevent dehydration of the chemical.

G. B. Banks and J. Buckingham. Application date January 11th, 1945. No. 590206.

The British abstracts published here are prepared with the permission of the Controller of H.M. Stationery Office, from specifications obtainable at the Patent Office, 25, Southampton Buildings, London, W.C.2, price 1/- each.